



# Rice Technology Toolkit Catalogue



**TAAT Clearinghouse**  
*Clearinghouse Technical Report Series 007*



# Rice Technology Toolkit Catalogue

© TAAT Clearinghouse, May 2021

The Technologies for African Agricultural Transformation (TAAT) is funded through a grant from the African Development Bank (AfDB) and implemented by the International Institute of Tropical Agriculture (IITA) in close collaboration with other centers of the Consultative Group for International Agricultural Research (CGIAR) and specialized institutions such as the African Agricultural Technology Foundation (AATF), the Forum for Agricultural Research in Africa (FARA), the International Fertilizer Development Center (IFDC) and others. For more information, email contact: [i.musabyimana@cgiar.org](mailto:i.musabyimana@cgiar.org) or [plwoomer@gmail.com](mailto:plwoomer@gmail.com).

*This report may be reproduced in its entirety or in part for non-commercial application, provided that the TAAT Clearinghouse is acknowledged.*

**Front cover photographic credit:** Paddy field cultivated with an Advanced Rice Variety for Africa, ARICA (left), and a motorized thresher for threshing rice paddy close to the farm with lower labour costs (right). Photo credits: International Rice Research Institute (IRRI) and Africa Rice Center (AfricaRice).

## **Correct Citation:**

TAAT Clearinghouse. 2021. Rice Technology Toolkit Catalogue. Clearinghouse Technical Report Series 007, Technologies for African Agricultural Transformation, Clearinghouse Office, IITA, Cotonou, Benin. 32 pp.



# Rice Technology Toolkit Catalogue



A Report by the Technologies for African Agricultural  
Transformation Clearinghouse, May 2021

---

## Table of Contents

Purpose and Introduction .....	1
Technology 1. Superior Rice Varieties for Lowlands and Uplands .....	3
Technology 2. Climate-Smart Rice Varieties .....	5
Technology 3. Aromatic and Soft-Cooking Rice Varieties .....	7
Technology 4. Engineered Irrigation Surfaces and Water Lifting .....	9
Technology 5. Deep Urea Fertilizer Placement .....	12
Technology 6. Foliar Micronutrient Addition for Healthier Rice .....	15
Technology 7. Motorized Rice Paddy Weeders .....	18
Technology 8. “RiceAdvice” Digital Support for Best Practices .....	20
Technology 9. Axial Flow Thresher and Quality Milling .....	22
Technology 10. GEM Parboiling and Rice Flour Production .....	25
TAAT as your technology broker of choice .....	29
Conclusions .....	31
Information Sources .....	31
Acknowledgements .....	32

---

## Purpose and Introduction

This catalogue describes a suite of technologies related to the modernization of rice production in Africa. It is based upon the combined efforts of the Project Platform for Agricultural Solutions (ProPAS) which is information from the internet, and the Technologies for African Agricultural Transformation (TAAT), a large collaborative program that is deploying agricultural solutions across the continent. Both sources aim to connect proven technologies to those who need them; however, each of them uses a different approach to achieve its goal. Rice is one of TAAT’s priority commodities because of its huge importance to food and nutritional security, import substitution and rural development in general across Africa. It is also targeted as an agro-industrial crop for processing and trade in the national, regional and world markets. In the course of its compilation, ProPAS has accumulated several technologies that specifically address this commodity and we have compiled them into a “technology toolkit” designed to advance the adoption and investment into the proven agricultural solutions. This is the third of several catalogues that we intend to produce as a joint ProPAS-TAAT activity.

**About ProPAS.** The Product Platform for Agricultural Solutions (ProPAS) provides a mechanism to compile and access innovations, management technologies and products needed for Africa’s agricultural transformation. The platform provides two pathways: it permits users to enter their proven and promising solutions into a database, and then encourages others to sort through its options to reveal the suite of opportunities that can help meet their objectives. ProPAS results from the recognized need by the International Institute of Tropical Agriculture (IITA) to more

systematically compile and access the full range of agricultural solutions available to modernize and transform African agriculture. Its overall goal is to accelerate the process of agricultural transformation in Africa. Many solutions are available to improve and modernize Africa's food systems but those who are expected to benefit from them most are often unaware of the best options at hand. In addition, more solutions are in the research and development pipeline that are best advanced through wider exposure and validation. Solution profiles are compiled and released in a systematic manner that involves submission by technology holders, entry into a user-friendly software platform, and use by an expanding base of clients. A small committee of agricultural experts oversees this process, but recognizes that its strength is through open-ended access to a marketplace of solutions. ProPAS is therefore managed through a three-phase process that involves solution submission, database management, and client access. The database allows for solutions to be identified through selection of several fields related to the form, type, commodity and target beneficiaries of a given solution, sequentially narrowing the number of platform recommendations.

**About TAAT.** The Technologies for African Agricultural Transformation (TAAT) is a program led by the International Institute of Tropical Agriculture (IITA) that has pioneered new approaches to the deployment of proven technologies to African farmers. TAAT arose as a joint effort of IITA and the African Development Bank (AfDB); it is an important component of AfDB's Feed Africa Strategy. TAAT is currently advancing 76 carefully-selected technologies through 88 interventions in 28 countries. It is organized around 15 "Compacts" that represent priority value chains and enablers whose interventions will unleash Africa's potential in achieving food security and advancing its role in global agricultural trade. Nine of these Compacts relate to specific priority value chains of rice, wheat, maize, sorghum and millet, cassava, sweet potato, bean, fish and small livestock. Weaknesses in the production of commodities are viewed as responsible for Africa's food insecurity, need for excessive importation of food, and unrealized expansion of Africa's food exports. Together these Compacts design interventions in collaboration with national programs to introduce technologies and management innovations that are tailored to meet targets for agricultural development. In many cases, these targets are met through the implementation of projects emanating from sovereign country loans awarded by development partners, including banks and TAAT's role in the design, planning and execution of these projects is becoming a vital element of their success.

**The TAAT Top 100 Technologies.** The Clearinghouse developed a database of the Top 100 Technologies that are transforming African agriculture. It is based upon the approaches adopted by the TAAT Commodity Compacts and those from the CGIAR Collaborative Research Programs that are recently described as ready for next user. These technologies are divided between those related to genetics and plant and animal breeding (23%), those based upon the use of digital information (3%), production input products of proven efficacy (21%), crop and animal management technologies of utility within agricultural extension messaging and campaigns (27%) and appropriately designed labour-saving equipment (26%). These technologies have a direct role towards the achievement of the Sustainable Development Goals in relationship to farm productivity, food security and hunger reduction, improved household nutrition and diets, economic growth, climate-smart innovation and improved human equity. These technologies form the basis for selecting entries into ProPAS.

**The Top 10 Rice Technologies.** This catalogue presents ten technologies that serve to modernize production and processing of rice in Africa. These technologies include: 1) high-yielding varieties for lowland and upland rice paddies (NERICA lines), 2) advanced hybrid varieties with drought tolerance and disease resistance (ARICA lines), 3) aromatic "Basmati" rice varieties with good palatability and higher market price (ORYLUX lines), 4) levelling and engineering of soil surfaces for efficient irrigation, 5) better nitrogen fertilization by deep urea placement, 6) input of micronutrients via foliar spraying to address deficiencies, 7) power weeding for improved paddy management and rice yields, 8) "RiceAdvice" guidelines for best crop agronomy and fertilization, 9) motorized threshers and millers to enhance post-harvest value add, and 10) parboiling for improved grain quality and flour production. Details on each of these ten technologies are provided in this catalogue.



## Technology 1. Superior Rice Varieties for Lowlands and Uplands (e.g. NERICA)

**Summary.** Improved rice cultivars suitable for a broad range of growing areas in Africa were developed by breeders through crossing landraces from the continent with high yielding Asian varieties or introduced after extensive multi-location testing. These new varieties have greater yield potential and are more resistant to pests and diseases compared to the traditional varieties which were widely cultivated in Africa. The most widely cultivated of these superior varieties include the NERICAs (New Rice for Africa), including both upland and lowland types; Sahel varieties bred specifically for irrigated lowlands; WITA varieties mainly targeting rainfed lowlands but also including varieties adapted to both irrigated and rainfed lowlands; ARICAs (Advanced Rice for Africa) which include upland, rainfed lowland and irrigated lowland types; and more recently, hybrids. Use of these superior rice varieties has allowed farmers in Sub-Saharan Africa to increase economic yields and production levels across the various ecologies, giving rise to improved livelihoods of smallholder farmers, millers and other actors in the rice value chain. For more information contact Dr. Ester Pegalepo of AfricaRice by email at [e.pegalepo@cgiar.org](mailto:e.pegalepo@cgiar.org).



Close-up of NERICA rice at grain filling stage.

**Technical Description.** NERICA varieties were developed from crosses between Asian and African rice varieties and include both upland and lowland types. Lowland NERICAs have yield potentials of 6-7 tonnes grain per hectare under non-water limiting conditions and upland NERICAs have yield potentials 4-5 ton/ha under non-water limiting conditions. Many NERICA varieties tolerate low levels of weed infestation and short-term drought, have moderate levels of resistance to major diseases such as rust and leaf blight, as well as pests such as nematodes and leaf miners. Sahel varieties were specifically bred for irrigated lowlands in semi-arid regions of Africa and have with yield potentials of 10-12 ton/ha. Sahel varieties include early maturing varieties that are suitable for double cropping and intensification in irrigated lowlands. Some Sahel varieties are of medium duration and mainly target wet season production. The most widely grown Sahel variety is heat tolerant which is a good adaptation for the Sahel region. WITA varieties are mainly intended for rainfed lowlands but also include varieties for irrigated lowlands. Many of the WITA varieties have good levels of iron toxicity tolerance which is one of the most widespread soil problem in rainfed lowlands in Africa. ARICA varieties are the result of extensive testing by an Africa-wide Rice Breeding Task Force, and include upland, rainfed lowland and irrigated lowland types. More recently, a series of three-way hybrids that possess yield potentials of 12-13 ton/ha was developed by a breeding program. One of these hybrids (AR051H), released across Senegal in 2017, is widely cultivated, and has an earlier peak maturity than Sahel 108 and a superior yield potential of 11 ton/ha.

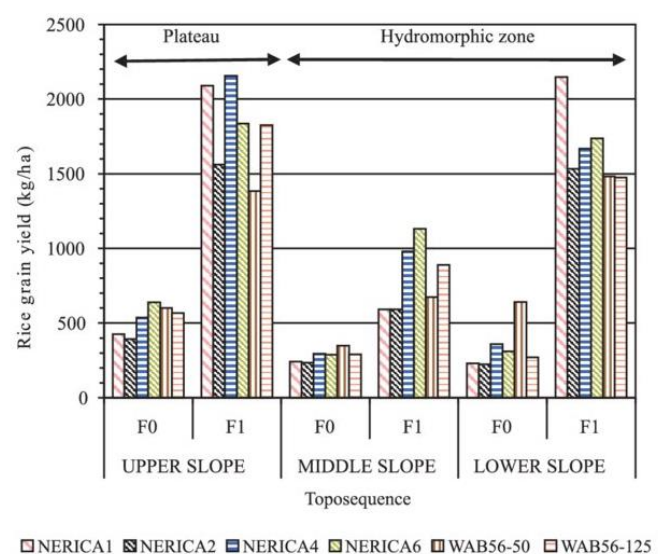

Yield benefit of NERICA lines along topographic gradient (F0: unfertilized, F1: fertilized).

**Uses.** The new rice cultivars are well-adapted for paddy production in Africa after having been extensively tested by AfricaRice and national breeders. Among the different groupings of improved and high yielding rice varieties, NERICAs are the most widely cultivated, with more than 800,000 hectares of farmland in seven West African countries, and another 600,000 hectare across the rest of Sub-Saharan Africa. For the upland ecologies, NERICA 4 is the most widely cultivated whilst in the lowlands NERICA-L-19 is the most widespread. A large selection of NERICAs is available for seed suppliers in Sub-Saharan Africa that are adapted to particular conditions on the continent giving farmers the ability to find a suitable variety for their purpose. The Sahel 108 variety which has superior milling recovery in addition to its high yield is widely cultivated in irrigated systems across Senegal and Mauritania. In Mali, the Sahel 159 variety (locally called WASSA) is widely cultivated in irrigated lowlands. WITA varieties are preferred by rice farmers in rainfed lowland systems from West Africa to East Africa. WITA 4 is the dominant variety in Nigeria, and WITA 9 in Ivory Coast and Uganda. ARICA varieties which have been recently released are quickly gaining in traction across several African countries, for instance ARICA 3 in Mali, and ARICA 6 and 18 in Guinea Conakry.

**Composition.** More than 82 NERICA varieties have been released across Sub-Saharan Africa, which includes 60 types for lowland paddies, 18 for upland cultivation and four for irrigated systems. A total of 19 Sahel varieties have been released and are cultivated in irrigated lowlands of Senegal, Mali, Mauritania, Nigeria and Malawi. Nine WITA rice varieties are available to farmers, with WITA 4 and WITA 9 being the most popular in rainfed lowlands. For ARICA, to date 10 varieties have been released in 8 African countries. For hybrid varieties, in total 50 lines were developed and the first one has been successfully released across Senegal. Several breeding programs are making continued efforts to develop rice varieties and hybrids that are higher in yields, more climate-resilient and better respond to consumer preferences than present varieties.

**Application.** NERICA, Sahel, WITA and ARICA varieties are cultivated as any normal rice crop following best soil and fertilizer management prescribed for particular growing areas and conditions. Hybrid varieties, due to their higher tillering capacity and vigour, require different agronomic practices from conventional varieties with regard to planting density and fertilizer management. Rice can be planted manually or mechanically by sowing seed directly in the fields (drill/dibble/broadcast), or through transplanting of seedlings from nurseries into fields which requires additional labour but is very effective in attaining optimum plant population, controlling weeds and achieving maximum yields. Fields in both lowlands and uplands areas are usually divided into squares and rectangles by constructing bunds, i.e., low embankments made of soil, which facilitate the control of water from streams and rain water.

**Commercialization.** The superior rice varieties for lowlands and uplands are commercially available in many African countries, particularly from the private seed companies.

**Start-up Requirements.** Scaling the cultivation of superior rice varieties for Africa requires that: 1) Breeders and seed enterprises develop lines that are adapted to conditions in the growing areas, 2) Awareness-creation with farmers about benefits of planting the improved rice varieties which are resilient and adapted to climate change for food production and risk mitigation, and 3) Creating equitable access to agri-inputs and financial support for local suppliers and smallholder farmers that catalyses investment and purchase of seeds of these improved and high yielding rice varieties.

**Production Cost.** Development of NERICA varieties involves advanced breeding techniques in the lab and screen house, and extensive testing in the field. This process requires significant investment from commercial breeders. Presently, large agro-input suppliers are currently selling seeds of these high yielding varieties at US \$0.8 to

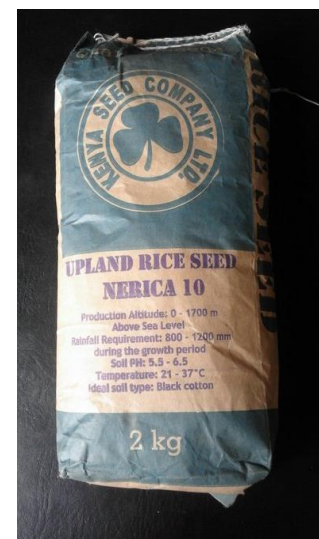

\$1.2 per kilogram. However, the cost of breeder seed which is produced by research institutions and from which foundation and then certified seeds are produced by private sector, is usually between US \$5 to \$8 per kilogram.

**Customer Segmentation.** Small-scale and commercial rice producers, and seed companies and multipliers operating in uplands, rainfed lowlands and irrigated lowlands, stand to benefit from these high yielding varieties. Rice millers also benefit from these varieties because the increased rice production keeps their mills operational longer and thus increase the profitability of their investments.

**Potential Profitability.** Surveys demonstrated that farmers in Nigeria who cultivate NERICA varieties are harvesting substantially more than those growing common non-improved varieties of rice, with average grain yield gains of 0.7 ton/ha without fertilizers and 1.7 ton/ha with input of fertilizers. Scaling programs for community-based multiplication and marketing of NERICA varieties in Benin, Gambia, Ghana, Guinea, Nigeria, Mali and Sierra Leone found that such enterprises can achieve an increased rate of return on initial investments ranging from 25% to 39%. Evidence from Uganda shows that the release of NERICA varieties has played a major role in the nine-fold increase in the number of farmers growing the crop, which has almost halved its rice imports from 60,000 tonnes in 2005 to 35,000 in 2007, saving roughly US \$30 million in the process.

**Licensing Requirements.** A certificate for the multiplication of seeds of these high yielding varieties has to be obtained by seed producers. Each country in Sub-Saharan Africa has licensing requirements for seed multipliers to produce and sell foundation or certified seeds on local markets. All these high yielding varieties are free of royalty, except for hybrids. AfricaRice and its partners provide appropriate legal frameworks that allow seed producers to access and multiply hybrid rice seeds in a cost-effective manner.

## Technology 2. Climate-Smart Rice Varieties (e.g. ARICA)

**Summary.** A new generation of high-performing and locally adapted rice cultivars has been launched since 2009 through breeding programs in Sub-Saharan Africa, to identify rice varieties that combine high yield potential with strong tolerance to the prevailing environmental stresses in SSA such as droughts, flooding and salinity. For instance, ARICA lines are being developed in response to needed resilience toward climate variation by combining hybridized traits related to heat and drought tolerance, as well as the ability to withstand episodic flooding and too rapidly evolving pathogens. These climate-smart varieties were developed through conventional breeding and also through more modern molecular breeding approaches. These climate-smart varieties, after introduction or development by AfricaRice, have been extensively tested by breeders in SSA leading to their release and adoption in several countries. Breeders' assessments of new lines are backed by field data collected over a number of years. These climate-smart rice varieties that were released across SSA have proven to be an avenue for boosting the levels of rice productivity and profitability as a means to advance this major food staple value chain. For more information contact Dr. Ernest Asiedu of AfricaRice by email at [e.asiedu@cgiar.org](mailto:e.asiedu@cgiar.org).

**Technical Description.** Climate-smart rice varieties are distinguished by their high yield potential; tolerance to diseases and pests, such

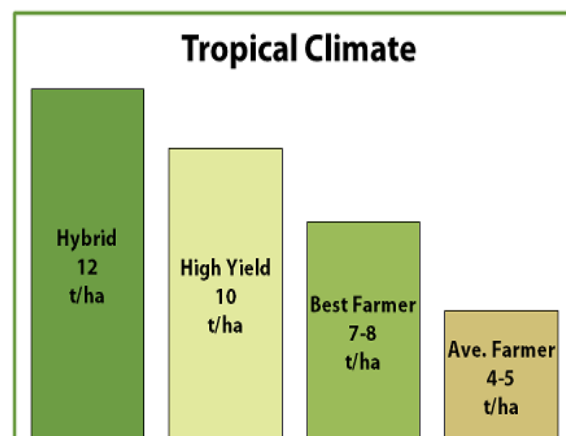

*Yield potential of ARICA lines (Hybrid) as compared to other types of rice varieties.*



as blast, bacterial leaf blight, rice yellow mottle virus; as well as abiotic stresses like drought, flooding, iron toxicity, cold and salinity. Breeders employ a three-line system to develop ARICA hybrid lines, involving backcrossing which gives new cytoplasmic male sterile germplasm with desired agronomic traits, then next out-crossing to obtain high seed yield, as later as test-crossing and microsatellite screening for identifying suitable restorer lines. A two-line breeding system for ARICA varieties is in place that relies on environmental genetic male sterility and has shown to achieve similar performance like the three-line system while being more economical. For breeding lines to be nominated as ARICA, they must consistently and significantly out-yield the best checks in at least one site over at least three seasons and possess acceptable grain quality. In other words, it must represent significant improvement on the current best variety. Extensive field validation has shown that the production levels of ARICA 1, ARICA 2 and ARICA 3 are respectively 20-44%, 50-111%, and 2-69% greater than for NERICA-L 19 which is in wide use by African farmers.

**Uses.** The multiple improved traits of ARICA varieties make them ideal for responding to challenges that are faced by farmers in different types of agroecosystems in SSA, going from lowland to highland areas, and dry sub-humid to humid climates. Tolerance of water and nutrient limitation and resistance to pests and diseases that is bred into these hybrid lines offer advantages for rainfed and irrigated rice cropping systems under a broad range of management practices (i.e., extensive or intensive fertilizer use, weed control measures). The growing collection of ARICA lines available from seed suppliers across SSA gives farmers the ability to find a suitable variety for their purpose.

**Composition.** A total of 18 ARICA varieties have been developed and tested in 30 African countries by the joint breeding task force through a participatory varietal selection method involving thousands of farmers. The varieties in the collection are designated for particular countries and types of rice cropping systems including rainfed or irrigate lowland and upland production, and even saltwater mangroves. Specialty traits like drought resistance, tolerance to iron toxicity and cold, pest/disease immunity and high protein content that are built into certain lines enable rice growers to address unfavourable conditions at local scale.

**Application.** A standard methodology developed by the breeding task force is being used by breeders to develop and certify ARICA varieties. This protocol enables scientists to analyze the data across sites and countries with confidence, knowing that the plant traits have been screened and same practices have been followed at all sites. ARICA varieties are cultivated as any normal rice crop following best soil and fertilizer management prescribed for particular growing areas and conditions. Rice can be planted manually or mechanically by sowing seed directly in the fields (drill/dibble/broadcast), or through transplanting seedlings from seedbeds into paddy fields. This latter practice requires additional labour but is very effective in controlling weeds. Fields in both lowland and uplands areas are usually divided into sub-plots by constructing bunds (low embankments made of soil or stones) which enable to rain water accumulation favourable moisture conditions.



*ARICA varieties on lowland paddy field.*

**Commercialization.** ARICA varieties are becoming commercially available but access to them is often best achieved through national programs until they become more widely commercialized.



**Start-up Requirements.** In terms of scaling advanced hybrid rice varieties there are several steps: 1) Breeders and seed suppliers need to develop ARICA varieties that are adapted to conditions in particular growing areas, 2) Awareness-raising with farmers about benefits of planting the improved type of rice in terms of greater production and risk mitigation, and 3) Creating equitable access and financial support for local suppliers and smallholder farmers that catalyses investments and purchases of ARICA rice.

**Production Cost.** Development of ARICA varieties involves advanced breeding techniques in the lab and screen house, and extensive testing in the field. This in turn requires significant investment from commercial and non-commercial breeders. The costs associated with producing these new hybrid lines are not substantially different from common improved rice varieties, and large agro-input suppliers are currently selling these hybrid seed for about US \$1.2 per kilogram.

**Customer Segmentation.** There is a highly segmented customer base for ARICA varieties including small-scale and commercial rice producers, seed companies, and food processors. Rice hybridization also attracts buy-in from national systems.

**Potential Profitability.** Economic analysis in different zones of Sub-Saharan Africa suggests that yield gains by switching to ARICA cultivars results in increased income of up to 40%. Multiplication and sales of hybrid rice varieties offers lucrative business opportunities for community-based and commercial enterprises.

**Licensing Requirements.** A certificate for the multiplication of ARICA varieties must be obtained by multipliers. Each country in Sub-Saharan Africa has licensing requirements for seed multipliers to produce and sell certified seeds on local markets as well. ARICA varieties are free of royalty, and AfricaRice is the custodian of public investments for developing and scaling of these new rice varieties across Sub-Saharan Africa.

### **Technology 3. Aromatic and Soft-Cooking Rice Varieties (e.g. ORYLUX)**

**Summary.** The excellent flavour and texture of aromatic and soft-cooking rice make these varieties very popular with consumers and provide them a larger market value than many traditionally cultivated types of rice that are considered less palatable. Nonetheless, production of these rice varieties by countries in Sub-Sahara Africa remains low and does not come near to fulfilling the consumer demand, mostly from urban areas, that in turn results in major importation from Asia. The main reason why SSA isn't more self-reliant is because farmers have very limited access to seed materials for aromatic and soft-cooking rice varieties that are adapted to prevalent growing conditions. In response to increasing consumer demand for such high quality rice, breeders from AfricaRice have developed or introduced a set of high quality rice varieties with Basmati fragrance and/or soft cooking quality for wider cultivation in Africa. Many of these varieties are non-chalky, translucent, slender and early maturing; characteristics that rival premium rice grown in other parts of the world. These high quality rice varieties include some ORYLUX, Sahel and ISRIZ varieties. Drawing on a premium quality and price, higher degrees of profitability can be realized by cultivating premium rice than with less desirable varieties, and thus gives rise to opportunity among both farmers and processing industries positioned along the rice value chain. For more information about this topic contact Dr. Saidu Bah of AfricaRice by email on [s.bah@cgiar.org](mailto:s.bah@cgiar.org).



*ORYLUX aromatic rice close to harvest maturity.*

**Technical Description.** Premium aromatic and soft-cooking rice varieties can be crossed with elite lines that are commonly grown in a region through conventional breeding techniques, whilst maintaining high yields and other beneficial agronomic traits in the process. Specific methods that overcome the low combining ability and heritability of ‘high yield’ traits between distant rice varieties enable breeders to create hybrid lines that are rich in aroma and taste, and offer farmers greater returns on investment than common, less palatable varieties. In this way, ORYLUX and aromatic Sahel rice varieties developed by AfricaRice, were conventionally bred from crosses of West-African adapted varieties and Basmati-type varieties from Asia. Soft-cooking rice varieties such as Sahel 210, ISRIZ-07 and ISRIZ-09 were developed through introductions of soft-cooking varieties or cross-breeding of African and Asian varieties. Widespread testing on smallholder farms in SSA demonstrated that these high quality rice varieties also possess high yield potentials, and moderate to high resistance to widespread diseases, and insect and nematode pests. Gaps in premium rice production across SSA can be rapidly closed by making seed from aromatic and/or soft-textured ORYLUX, Sahel and ISRIZ varieties more widely available to rice growers through local markets, and then ensuring offtake by food processors through active markets.

**Uses.** Aromatic and soft-cooking rice varieties offer a viable strategy for increasing the production of premium rice in all major growing areas of SSA because their traits are adapted to specific agricultural conditions as a result of cross-breeding with improved varieties. The selection of ORYLUX rice that has been developed is suitable for rain-fed systems but perform best in lowland valleys or with added irrigation. Aromatic NERICA 1 and WAB 638 are the two most widely cultivated improved aromatic varieties for upland systems in SSA. Meanwhile, aromatic Sahel varieties such as Sahel 177, 328, 329; soft-cooking Sahel 210; and aromatic ISRIZ varieties such as ISRIZ-07, 09 and 12 are primarily meant for the irrigated lowlands. ISRIZ-12 is also adapted to rainfed lowlands due to its drought tolerance. Seed from premium aromatic and soft-cooking varieties can be made available at large scale to rice growers through commercial seed supply chain systems that currently exist. Farmers growing premium quality rice need to have ready access to markets and processing facilities for turning the higher value of the crop into cash, which typically requires broader interventions that connect actors in the agri-food value chain.

**Composition.** A series of aromatic and soft-cooking rice varieties with different water requirements and yield potential, that are suited to the major growing areas of SSA, were released by national partners of AfricaRice. ORYLUX 1 reaches a grain harvest of 8 ton/ha in intensively managed and irrigated lowland paddies, and has been successfully adopted by farmers from Togo and Uganda. ORYLUX 6 has a potential grain yield of 6.5 ton/ha on rain-fed paddies in lowland valleys that reaches maturity in only 100 days, raising the possibility of double cropping. ORYLUX 6 is tolerant to prevailing diseases like blast and is especially popular in Benin, Burkina Faso, Cote d’Ivoire, Gambia, Liberia, Senegal and Togo. A total of 23 aromatic varieties are now available that target irrigated lowlands in the Sahel region of West Africa, such as Sahel 177, 328, 329, ISRIZ-07, ISRIZ-09 and ISRIZ-12. that have yield potentials of 7 to 11 ton/ha. The aromatic hybrid AR051H released in Senegal as ISRIZ-09 offer yields of 6 to 7 ton/ha and it combines aroma with soft-texture and high yield potential of that has a yield potential of 10 ton/ha on smallholder fields and milling recovery of 80%. Aromatic NERICA 1 and WAB 638 are also widely cultivated in Africa with WAB638 being highly preferred in Ivory Coast where it is called AKADI meaning “tasty” in the local Dioula language.



**Application.** Aromatic and/or soft-cooking ORYLUX, Sahel and ISRIZ varieties are cultivated in the same way as any type of rice, except for the aromatic hybrid ISRIZ-09 which requires a different planting density and fertilizer management. Fields are planted manually or mechanically by sowing

seed directly in the fields, or through transplanting seedlings into fields. In order to satisfy crop nutrient demand and achieve higher yields, there is need for mineral and/or organic fertilizers at recommended dosage, managing soil water contents through construction of low embankments around paddies, and controlling weeds through manual removal and use of herbicides.

**Commercialization and Start-up Requirements.** Newly developed aromatic soft-cooking rice varieties for Africa are becoming commercially available, most often in conjunction with national programs. Adopting premium rice varieties requires: 1) Breeders, farmers and food processors to identify varieties that match agronomic conditions and consumer preferences in growing areas and in local and urban markets, 2) Awareness-raising with value chain actors about the additional incomes that can be generated by cultivating premium fragrant rice or soft-cooking rice, and 3) Create equitable access to seeds of premium varieties and financial support for local suppliers and smallholder farmers that enable investments.

**Production Cost.** Seed companies in West-Africa are currently marketing certified seeds of aromatic and/or soft cooking varieties at US \$1.3 per kilogram. At common planting densities, there is need of 40-80 kg rice seed per hectare, depending on the ecology and planting method (direct seeding or transplanting). Drawing from economic analysis in Nigeria, other major investments by rice growers include labour costs for planting at US \$51 per hectare, fertilizer inputs at US \$105 per hectare, and harvesting and winnowing of grain at US \$200 per hectare.

**Customer Segmentation and Profitability.** While rice stakeholders are highly segmented, aromatic and soft-cooking rice varieties appeal most to commercial producers and their food processing buyers. Research in Senegal on willingness to pay for aromatic rice has shown that consumers attracted to fragrant rice are willing to pay 10% more than for non-aromatic types. An internal return rate of 30-80% can be achieved by farmers that grow premium varieties thanks to the high market value of fragrant and soft-cooking rice. The superior milling returns and cooking quality of premium varieties make them highly suitable for manufacturing of food products through which additional value is created. Aromatic and soft-cooking rice that is produced locally is sold at a discounted price of 3% to 6% in comparison to imported rice, benefiting consumers and processors.

**Licensing Requirements.** A certificate must be obtained from national seed regulatory authorities for the production of foundation and certified seeds of aromatic and soft-cooking rice varieties. Each country in SSA has licensing requirements for seed multipliers to produce and sell foundation and certified seeds on local markets. Aromatic and/or soft-cooking ORYLUX, Sahel and ISRIZ varieties are Regional Public Goods which have been registered in the ECOWAS regional varietal catalogue and are thus available for regional seed trade by private companies.

## Technology 4. Engineered Irrigation Surfaces and Water Lifting

**Summary.** The roots of rice must receive sufficient water from rainfall or irrigation in order to reach its yield potential and avoid moisture-induced stress. Proper delivery and drainage of water on rice farms hence plays a crucially important role for obtaining satisfactory levels of crop production and input use efficiency. Uneven land surfaces prevent the uniform movement of water and nutrients whereby creating unfavorable conditions, resulting in large variation of rice growth inside stands. Generally it is found that grain yields from rice paddies are reduced by 260 kg/ha for



*Laser-guided land leveling system with tractor.*

every 10 mm of variation in land surface level, with lower yields at the upper end. Conversely, better levelling of soils and installing furrows and embankments reduces the amount of water required for production, improves seedling survival rates, and suppresses weed encroachment. Better irrigation allows rice to mature more uniformly so it is harvested using less labor. Leveling and engineering of land surfaces must be closely aligned with the topography of paddy fields and carried out through minimal displacement of soil as it requires substantial labour investment. Rice paddies with appropriate surface designs also improve the cost-effectiveness of irrigation by greater reliance of gravity fed water from the water basin as compared to systems reliant upon water lifting. The technology of land leveling forms part of the 'Smart Valley' approach which involves participatory stepwise procedures that focus on the design of water-control infrastructure in rice paddies based on contexts and farmers' knowledge. For more information on this topic contact Dr. Sander Zwart of the International Water Management Institute by email at [s.zwart@cgiar.org](mailto:s.zwart@cgiar.org).

**Technical Description.** Soil surfaces in rice paddies need to be shaped into a straight horizontal or sloping plane for water from rainfall and irrigation to be evenly distributed across large crop stands. Levelling of the soil surface renders the greatest improvement of water supply and is the most widespread of all management interventions that is adopted by commercial rice growers in other parts of the world. Laser guided construction of level field planes in rice paddies greatly enhances maintenance of the soil moisture level and water use efficiency from the crop. In Cambodia and India, the soil engineering practice has shown to improve the germination rate for direct seeding, reduce total field labour by up to 30 person days, reduce weed infestations by up to 40%, and raise rice grain yields by 8% to 24%. Land leveling makes it possible to cultivate rice on larger-sized paddy fields and simplifies reliance upon mechanized farming since fewer embankments are needed to control the movement of water. Irrigation of paddies with well-designed surfaces enables highly intensive rice production, and can increase the number of harvests to 2 or 3 per year in major African growing areas. Farmers stand to earn large returns from investments on land leveling and that make this innovation financially viable for rice growers operating at medium to large-sized community level and commercial scale.

**Uses.** Technologies for soil surface engineering and strategic water lifting offer large opportunities to intensify rice production through improved water management and land preparation. The use of modern laser-guided leveling and irrigation systems is appropriate in lowland rice fields where uneven supply and low efficiency of water delivery reduce potential yields and profitability, as well as in upland paddies where irregular supply of water through precipitation severely challenges crop production. A range of small and large sized equipment for soil surface engineering and water lifting are commercially sold that suit the diverse agricultural and economic contexts of farmers in SSA. Hand-powered pumping systems can be used for shallow and deep wells or surface reservoirs, but their reach is limited because low pressures are generated and large amounts of labour is required. In contrast, motorized, wind driven, and even animal-powered pumps operate at sufficiently high pressure and energy efficiency to lift water over considerable distances and elevations.

**Composition.** Land leveling requires a small to large tractor depending on the volume of soil that must be moved. This displacement is assisted by specialty tractor attachments that receive directions from laser-guided topographic surveyor instruments. Skilled labour is needed to design surface engineering strategies and perform land measurements. Available systems for water lifting make use of suction, piston and direct action pumps that are fitted for diverse agricultural settings and specific irrigation volumes. The energy to run motorized water lifting technologies can be drawn from portable fossil fuel generators, as well as small wind, hydro or solar power plants, and combustion or gasification of agricultural residues and other renewable biomass wastes. The full application of these combined technologies is most appropriate when new rice production areas are being established, or existing ones improved or expanded.



**Application.** Constructing engineered soil surfaces and land levelling is easiest to perform when rice paddies are sufficiently wet but can also be performed under dry conditions. Preparatory steps involve ploughing the field from the center outwards (harrowing when dry), calibrating the topographic survey instruments and taking land measurements to design appropriate soil surfaces and plan soil movement. Tractor-mounted tools are then set up and leveling of fields performed, after which another land survey is made to verify the dimensions of soil surfaces. Soil surfaces typically do not have to be adjusted for ten years when properly engineered. The schedule and volume of water lifting into rice paddies is determined by the pattern and amount of rainfall, access to reserves in basins and rivers, and the production objectives of farmers. Commonly, there is need for additional irrigation just before and after planting rice crops, and at the critical stages of flowering and grain filling. Rice growers in SSA can access land levelling and water lifting technologies through collective investments by associations or agricultural service contractors.

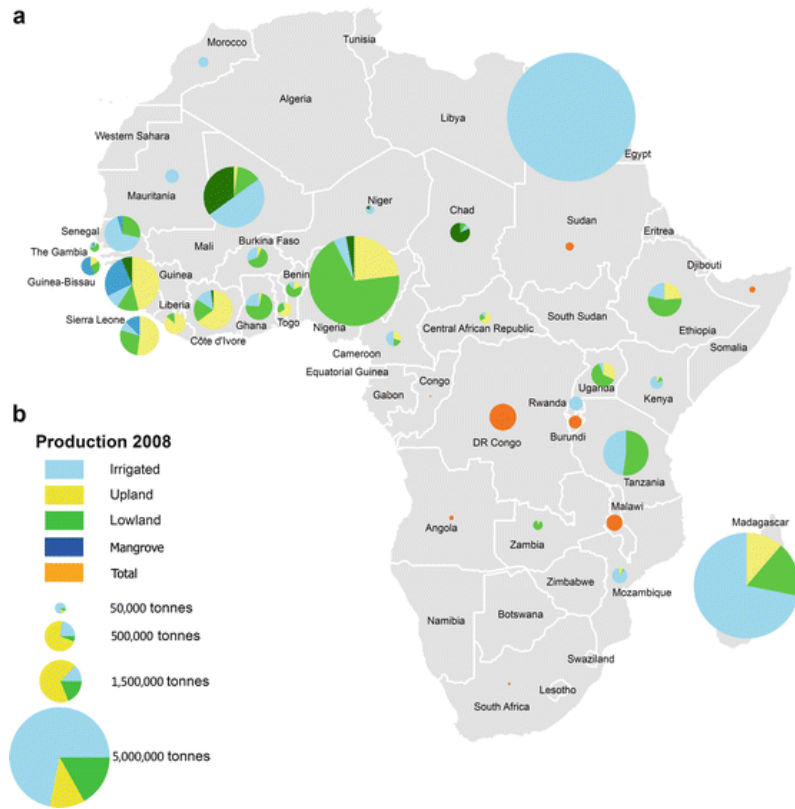

*Map of rice production levels and habitats in African countries.*

**Commercialization and Start-up Requirements.** The equipment for land levelling and water lifting is commercially available in most African countries and the approach holds commercial potential although currently this technology exists as a pilot activity in major rice production areas. Steps for farmers to adopt this technology include: 1) Raise awareness about benefits of engineered soil surfaces and deficit irrigation with rice producers and farm-service companies, 2) Identify methods for land levelling and water lifting that match the agricultural and economic contexts of rice growing communities, and 3) Provide small loans for producers and their associations to offset the initial costs of surface engineering and pay for rental of pumping systems.

**Production Cost.** Equipment for land leveling that is mounted on a tractor requires relatively small capital investment, with simple setups being sold at US \$4,700 to \$5,500 on global markets. Operational costs associated with surface engineering vary depending on the topography and the shape of the field, and the laser leveling technology that is used. In Brazil and India prices range from US \$190 to \$250 for moving 100 cubic meter of soil, corresponding to 10 mm correction over an area of one hectare. Land levelling of fields situated in lowlands, terraces and gently undulating landscapes typically requires less than 200 cubic meter of soil per hectare to be moved, whereas for the initial terracing and leveling in strongly sloping terrains this goes up to 500 to 1,000 cubic meter of soil per hectare. Additionally, larger than usual rates of fertilizer must be applied on areas where topsoil is removed and less fertile subsoil is exposed. Hand-operated pumps for water lifting from wells and rivers cost between US \$30 and \$180 depending on specifications. A solar powered pump with battery that can supply water for farms of up to 2 acres (0.81 ha) is sold at about US \$1,000.

High pressure pumps powered by petrol generators that are able to lift water over a vertical distance of 100 meter cost nearly US \$800 or more from local suppliers in Africa. Prices of high pressure water pipes cost about US \$65 for 50 meters.

**Customer Segmentation, Potential Profitability and Licensing Requirements.** This technology is intended for commercial rice growers, as well as farmer cooperatives and agricultural service companies that seek new opportunities. The investments associated with the construction of engineered soil surface in rice paddy fields can normally be recouped after two cropping cycles as a result of gains in economic yields and savings in the amount of irrigation water. In Brazil, it was shown that the average profit of irrigated rice production in levelled paddy soils was 3.4 times greater as compared to fields without engineered soil surfaces, and that the benefits recur and increase over several years. The economic gains of engineered soil surfaces are greatest when rainfall is limited, excessive or irregular, and lowest for rice crops that are affected by a biotic stress, factors that have no linkage with irrigation and drainage factors. Low-cost water lifting and distribution technologies have been scaled by the International Water Management Institute with rice farmers in Mali, Burkina Faso and Nigeria that has enabled them to irrigate rice during the off-season. They have expanded cultivated area and started double rice cropping. Farmers often require regulatory approvals and licenses in most countries of SSA to utilize surface water for irrigating rice crops. The equipment for land levelling and water lifting are commercial goods, and manufacturing companies hold the intellectual property rights for these technologies.

## Technology 5. Deep Urea Fertilizer Placement (Nitrogen Management)

**Summary.** Nitrogen (N) is a key yield determining nutrient in cereal production, especially in rice production. However, it is highly mobile in soil ecosystems and up to 2/3 of N applied through broadcasting gets lost. Better management of N fertilization by farmers in rice production offers substantial opportunity for enhancing grain production, nutrient use efficiency and profits margins, as well as reducing greenhouse gas, mainly N<sub>2</sub>O emissions associated with broadcast application of urea. Deep placement of urea in paddies involves placement of compacted prilled urea at 7-10 cm deep between four rice plants seven days after transplanting. In presence of water, the briquette releases N in the ammonium form, which is available for uptake by the crop all along the cropping cycle. This method of fertilizer application significantly reduces the recommended rates of urea, improves N use efficiency and increases paddy yields and quality of rice grain. Scaling programs for deep placement of urea by rice farmers have shown to be promising for intensification of rice production in smallholder farmers' settings. Urea deep placement (UDP) results in reduced costs, increased incomes, and ultimately reduced food insecurity and less importation of rice using limited foreign reserves. For more information on this topic contact Dr. Ekwe Dossa of the International Fertilizer Development Center by email at [edossa@ifdc.org](mailto:edossa@ifdc.org).

**Technical Description.** Rice farmers in Sub-Saharan Africa usually broadcast basal NPK fertilizer and then plough it into soil at shallow depth before seedlings are transplanted, followed by one or two applications of urea by top dressing onto paddies when crops are tasselling and grain is filling.

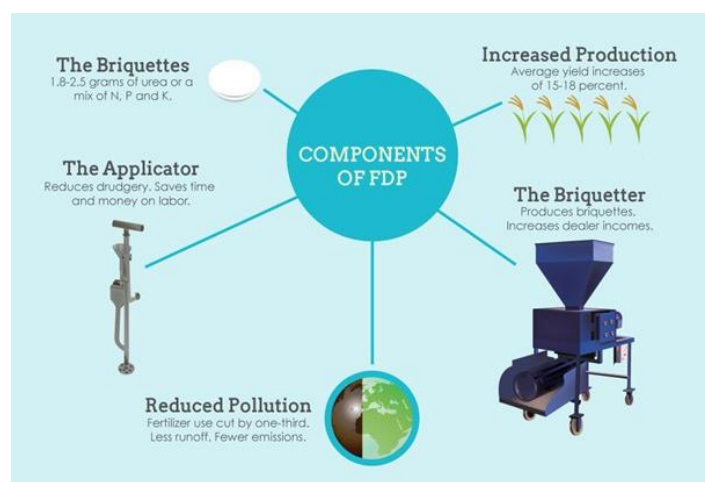

*Schematic of entry points and benefits of urea deep placement technology for crops including rice.*

Under this conventional approach to rice fertilization, plants take up only 25% to 40% of the applied N while the remainder is lost through runoff, volatilization and nitrification/denitrification. Denitrification contributes to greenhouse gases through production of N<sub>2</sub>O. These emissions are strongly associated with global climate change and changing weather patterns. Nitrification produces nitrate, a very mobile element which contaminates surface and groundwaters. Deep placement of urea makes use of large granules named supergranules or briquettes that are placed between four rice plants at a depth of 7-10 cm within seven days after transplanting. In presence of water, the majority of the N remains in the form of ammonium, which is less mobile than nitrates. As a result, more N is available to the crop throughout its growth cycle, with just one application as opposed to the two or three fertilizer applications that are required when urea is broadcast in a rice field. Consequently, losses of N to the atmosphere, groundwater and waterways are significantly reduced and only about 4 percent of the N is lost to the environment compared with about 35 percent when N is broadcast. Likewise, rice crops have been shown to take up about 70% of N from urea fertilizers when deep placement methods are used compared with 35% when urea is broadcast.

**Uses.** Deep placement of urea fertilizer is appropriate for small-scale and commercial rice farmers in major production zones of Sub-Saharan Africa in irrigated conditions or lowlands with water control. It performs best in heavy soils with low percolation rate (high soil clay and silt content). Suitability mapping showed that deep urea placement has a high potential to increase yields and nitrogen use efficiency on more than 46,000 hectares of rice paddies in Ghana (39% of growing area), and more than 21,000 hectares in Senegal (23% of growing area).



*A double handful of urea supergranules.*

**Production.** Urea Supergranules are produced by compacting ordinary prilled urea through a briquetting machine. This is a physical processing without any chemical ingredients. The granulation process can also be applied to other fertilizers such as Diammonium Phosphate (DAP) or Muriate of Potash (MOP). The weight of the supergranules varies depending on the specific weight of the fertilizer that is being granulated. Urea supergranules are spherical tablets with a diameter of 1.5 cm (1.8 grams) or 2 cm (2.7 grams) diameter. Many fertilizer manufacturers and agro-input dealers in Sub-Saharan Africa already have urea products among their products that can be used to produce briquettes for deep placement using a briquetting machine, and specialty briquettes are increasingly being marketed across rice-producing countries. A variety of mechanized and hand-operated tools for drilling fertilizers deep into soils is available and sold internationally. Use of these tools significantly reduces labor associated with this spot application method.

**Application.** For deep placement methods, urea supergranules or briquettes are usually drilled into soils in the middle of every four rice plants at 7-10 cm deep 1 week after transplanting at 20 cm x 20 cm spacing in order to derive optimal benefit from N uptake and grain production. Urea fertilizer must be placed at the correct



*Application of urea supergranules to rice using specialized handheld drills for deep placement.*

position with respect to the expanding root systems of rice, and requires the crop to be sown in carefully spaced lines rather than established from broadcast seed. Most smallholder farmers use hand application for placement of the supergranules. However, handheld drill can be used for placement of the supergranules since it allows consistent placement and speeds up the work. This technology is best applied to high performing varieties of rice of short to medium cycle (90-120 days) under best agronomic practices for ensuring maximal benefits in the short and long term.

**Start-up Requirements and Production Cost.** Unfortunately there is no widespread supply system for urea supergranules but it is possible to manufacture briquettes using imported from Bangladesh small-sized machines. These machines cost between US \$2,500 to \$5,000 each, and are well-suited for small-scale production. These machines involve relatively simple compaction technology, but require high quality component

parts and high precision in design and operation. Commercially available urea granular fertilizer (46-0-0) is used to produce these supergranules through a compaction process with the resultant product is referred to as a "briquette" that has the same chemical analysis as commercial urea fertilizer. This product is best introduced

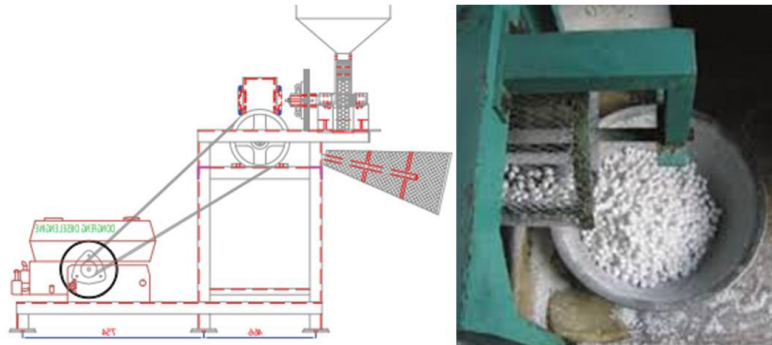

*Schematic diagram (left) and outflow (right) of a simple urea briquetting machine designed by IFDC.*

through established fertilizer input supply and marketing systems involving agricultural input dealers, cooperatives, agriculture input parastatals, and others. IFDC has been supporting local smiths in the manufacturing of the briquetting machine and the applicators as well. Local manufacturing of these tools are essential to speed up dissemination of the UDP technology in Africa. To scale this technology the following steps are required: 1) Manufacturers and dealers supply urea supergranules and briquettes, and mechanized drills for deep placement within local markets, 2) Awareness-raising of rice farmers about the benefits of the fertilizer deep placement method to grain production, agronomic efficiency, drought resilience and the environment, and 3) Creation of equitable access and financial support for local suppliers and smallholder farmers that catalyses scaling of deep urea placement. Urea supergranules cost less than briquettes containing multiple nutrients, with wholesale prices of major suppliers ranging between US \$0.40 to \$0.80 per kilogram. At a minimal recommended rate of 0.25 ton fertilizer per hectare this results in an expense of US \$100 to \$200 for farmers. Larger drills needed for mechanized operations are under development.

**Customer Segmentation and Potential Profitability.** This technology is intended for both small-scale and commercial rice farmers, and local fertilizer supply companies. A piloting program on deep urea placement in major rice production zones across seven countries in West Africa conducted by IFDC found that the improved fertilizer application method increased grain yields by 30% compared to the conventional urea fertilizer broadcasting. The high degree of nutrient uptake accomplished by deep placement of fertilizer is allowing farmers to use less fertilizer for higher yields. Use of deep fertilizer placement technology must be aligned with other agronomic practices including use of improved varieties (see Technologies 1 to 3) and effective weed control.

**Licensing Requirements.** The International Fertilizer Development Center holds the patent protection for the urea briquetting unit. No licenses are needed by farmers for the fertilizers and equipment to carry out deep placement in their rice paddies. Deep placement of urea fertilizer for rice growing areas in Sub-Saharan Africa is developed and scaled by AfricaRice and IFDC. The manufacturing of fertilizer briquettes and mechanized drills is done by the private sector.



## Technology 6. Foliar Micronutrient Addition for Healthier Rice

**Summary.** Rice crops require a small but adequate amount of elements other than nitrogen, phosphorus and potassium (macronutrients) including calcium, sulfur and magnesium (secondary nutrients), and iron, copper, zinc, manganese, molybdenum and boron (micronutrients) to achieve optimal levels of grain yield and nutritional value. Low availability of such other nutrients in soils across many African rice growing areas is becoming a concern

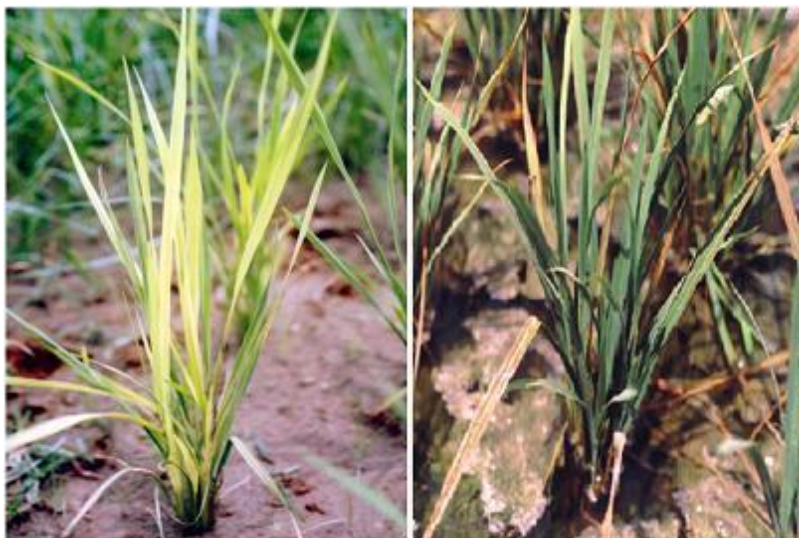

*Symptoms of iron deficiency in rice (left).*

owing to the continuous cultivation of lands with no or insufficient replenishment of nutrients exported by the crops, and the long term use of blanket fertilizer mainly made of N,P and K for most crops irrespective of soil conditions. Spraying leaves and stems of rice crops with specialty liquid mixes of micronutrient fertilizer offers a practical and economical strategy to ensure rice crops have all necessary elements during critical growth stages. The technology doesn't require elaborate investment or infrastructure and is readily adopted in rice growers. At the same time, it is important that this technology be applied where needed, and that the need for micronutrients be properly diagnosed and confirmed through field trials. Note that this technology is not necessitated by all rice producers. For more information on this topic contact Dr. Ekwe Dossa of the International Fertilizer Development Center by email at [edossa@ifdc.org](mailto:edossa@ifdc.org).

**Technical Description.** Micronutrients are mineral elements that crops need in small amounts to carry out essential metabolic processes such as photosynthesis and protein assimilation. Continuous or intermittent water logging of soils in rice paddies cause immobilization and leaching of iron, magnesium, calcium, copper, zinc, manganese and boron that substantially limit availabilities for crops. Under water logging conditions, iron toxicity occurs rather than iron deficiency. External input of micronutrients via concentrated mineral forms is a powerful means to tackle deficiencies in agricultural fields, but their large price tag necessitates efficient delivery to crops for ensuring financial viability. Very high levels of plant uptake are achieved when micronutrients are sprayed on leaves and stems, which makes that much lower dosages need to be applied in comparison to when the same fertilizers are placed into the soil. It is crucial micronutrient deficiencies in rice paddies are accurately diagnosed on the basis of concentrations in soil, grain and stover to make sure farmers spray only those elements that are limiting and receive the highest possible return. Alternately, the importance of spraying a specific micronutrient should be confirmed through nutrient omission trials where the crop response to the addition or omission of a specific element is evaluated when all other nutrients are kept at near optimal levels. The different chemical make-ups of micronutrient fertilizers may cause interactions, which can be positive, neutral or negative, so appropriate formulations have to be used to achieve high levels of bioavailability, yield effects and nutrient use.

**Uses.** Foliar application technologies for micronutrient fertilizers can be implemented in any rice production zone of Africa because it is easy to adapt formulations and spraying methods for different agricultural settings. Many rice growing areas of Africa are plagued by micronutrient deficiencies, but the limiting element and underlying reasons are diverse, which makes that the practice has to be used in targeted fashion to increase yields and incomes of farmers. Some micronutrient deficiencies are expressed only after macronutrient needs are met. Available information on soil characteristics and population density allow identifying where risk of micronutrient deficiencies is greatest. In this way, particular regions across the sub-humid savannahs of West and Southern Africa, and humid highlands of East Africa have been distinguished that are prone to shortages of zinc, copper and manganese.

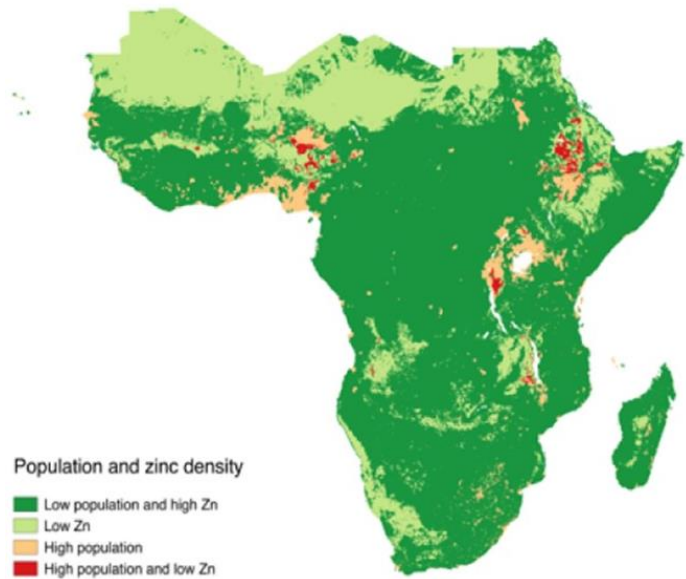

*Hotspots of zinc deficiency in SSA.*

**Composition.** Micronutrient fertilizers used in foliar application contain elements such as zinc, copper, iron, boron, molybdenum and manganese, most of the time in chelated forms to prevent interactions with soil constituents and environment and achieve high levels of plant uptake. The micronutrient elements come in the form of mineral salts with sulfates or ammonium, and silicates with oxygen, or organic chelating agents, which can be made into products with a single element, or a composite or blend of multiple elements depending on the soil needs. Most micronutrient fertilizers for foliar application are sold in a concentrated liquid form containing emulsifying agents that ensure a uniform delivery and adhesion on the plant for maximal uptake. Some types of micronutrient fertilizer are sold as dry powder that have a longer shelf-life as compared to liquid forms but need to be dissolved in water before application.

**Application.** Appropriate rates of nitrogen, phosphorus, potassium and other secondary nutrients must to be supplied to the rice to allow optimal response of the crop to micronutrient application. Rice is typically sprayed with micronutrients starting from six to eight weeks after planting when the canopy of the stands has covered most of the soil, and then at critical stages of the production cycle like the onset of flowering and grain filling. Concentrated micronutrient fertilizers are first diluted by addition of water in the spraying machine according to dosage recommended by the manufacturer of the chemical or the rice extension services. A nebulizer sprayer that disburse small droplets across the rice canopy works best. Application strategies range from hand operated knapsack sprayers,



*Spraying of the rice canopy with liquid micronutrient fertilizers using power sprayers.*

power backpack sprayers fully automated tractor attachments. Spraying of rice fields is best performed when the crop is not in direct sunlight, and bees and other pollinating insects are not active; making sure no rain is predicted so micronutrient get fully absorbed by plants. Workers need to wear protective clothing, eye gear and mouth masks when spraying to avoid exposure.

**Commercialization and Start-up Requirements.** A broad range of micronutrient fertilizers for foliar application to rice crops is commercially sold by agricultural input companies across SSA. A number of steps need to be taken for scaling the technology: 1) Asses the specific micronutrient deficiencies and imbalances in rice paddies that limit grain yield and nutritional value., 2) Inform rice farmers and agrodealers about the higher production level and market value of grain that can be achieved through foliar micronutrient addition and 3) Formulate appropriate rates, mixes and schedules for foliar micronutrient application at critical stages of the production cycle.

**Production/Application Cost.** Retail prices of micronutrient fertilizers vary depending on the elements, their forms of presentation and other chemical ingredients involved (chelating agents, emulsifiers etc.). The cost per kilogram of microelement in fertilizers amount to US \$4.3 for zinc sulfate, US \$16.2 for zinc chelate, US \$6.0 for iron sulfate, US \$6.2 for sodium pentaborate and US \$14.6 for copper sulfate. Hiring skilled labour equipped with knapsack sprayers to apply micronutrient onto the canopy of rice crops roughly costs US \$25-30 per hectare. Quality agricultural knapsack sprayers with a tank of 20 liter are sold at US \$30 to \$45, and protective kits for one person at US \$40. For commercial and large scale farming, renting tractor-mountable sprayers costs approximately US \$100 to \$300 per hour and a tractor another US \$70 to \$150 per hour, but with this equipment it is possible to apply up to 4 hectares of rice paddies per hour.

**Customer Segmentation and Potential Profitability.**

Micronutrient fertilization of rice crops is intended for use by both small-scale and commercial producers through distribution via agro-dealer networks, and as part of rental and consulting by service providers. Spraying liquid micronutrient fertilizers over the canopy of rice crops offers the most cost-effective method for tackling deficiencies and allows larger returns on investment than any other method for delivering specialty fertilizers. Some granular fertilizers are coated with micronutrients and are equally effective if the soil is not acidic. A study in Egypt on NPK fertilized rice crops found that paddy fields where zinc was applied through foliar techniques at a rate of 2.5 kg/ha and where dry granules were incorporated in the soil, the rate of 15 kg/ha resulted in the same grain yield, suggesting that spraying is six times more efficient. Zinc contents of grain were also highest for the foliar application technology. In Brazil and Malaysia, foliar application of zinc, copper and boron to rice crops has been shown to increase grain yield up to 30%, as well as strengthen resistance to fungal diseases. Large gains in the nutritional value of rice are achieved with low inputs of micronutrient fertilizers.

**Licensing Requirements.** The formulations of micronutrient fertilizers are typically protected as trade secrets. Knowledge of fertilizer composition is provided by manufacturers that allow easily calculating desired combinations and input rates. Information about the benefits of foliar micronutrient addition on rice grain yields and nutritional value is available as Regional Public Good from research institutions and private fertilizer companies.



*A concentrate with balanced combinations of micronutrients marketed by Yara.*



## Technology 7. Motorized Rice Paddy Weeders (Cut and Bury)

**Summary.** Weeds are one of the major problem for millions of smallholder rice farmers in Africa. For the most part, weeds are controlled using hand tools and this places a burden upon available labour. Sub-optimal management of weeds is responsible for grain yield losses of at least 2.2 million tons per year across Sub-Saharan Africa, losses valued at US \$1.45 billion. Small-sized motorized weeding equipments for weeding between the rows of rice are available that greatly facilitate weeding operations and reduce labour requirements in comparison to manual weeding methods. The low capital costs and high efficacy of these mechanized technologies bode well with smallholder rice farmers, and has the potential for widespread scaling similar to what occurred in rural communities of Asia and South-America over the past decade. Improvements of weed control in paddy fields achieved with simple motorized equipment are directly increasing rice grain production and quality, and reducing needs of fertilizer input and additional irrigation. For more information on this topic contact Dr. Elliott Dossou-Yovo and Dr. Kalimuthu Senthilkumar of AfricaRice by email at [e.dossou-yovo@cgiar.org](mailto:e.dossou-yovo@cgiar.org) and [k.senthilkumar@cgiar.org](mailto:k.senthilkumar@cgiar.org).



*Rice paddy overgrown by sedge weeds.*

**Technical Description.** Walking equipments designed to uproot, cut and bury weeds within the lines of evenly planted rice crops make it possible for one person to clear one hectare of paddy field in ten hours. If performed using manual labour and hand tools this same operation requires at least 100 hours. The specific design of the weeders ensures minimal disturbance to roots of rice crops and soil surfaces of fields. Litter from cleared weeds decomposes underground where it releases nutrients to crops. Weeding blades are propelled by small engines of one horsepower that limit their weight and allows for easy passing through fully soaked paddy soils, able to clear two rows at a time. The rotation of blades provide forward traction to the machine while the floater provides stability of weeding operation, and the width between blades has to be aligned with the spacing between rows of the rice crop. Farmers can utilize motorized weeding technologies to clear paddy fields as soon as rice plants have sprouted and through the time that the canopy closes and weeding is no longer needed. Hands-on demonstrations of rotary power weeders with rice growers in Tanzania and Madagascar found that 85% of farmers consider it to be a cost-effective and time-saving option for clearing weeds from paddy fields. Walking equipments with rotary blades typically clear 70-80% of weeds from rice fields in one pass, but nonetheless produce similar grains yields as when more than 90% of weeds are removed by hand.

**Uses.** Unsatisfactory weed control is one of the main limiting factor for rice production across Africa due to widespread dependence on manual weeding and low levels of herbicide application. Motorized weeding units are technically and financially suitable for both small-scale and commercial farmers, and are available in a variety of sizes. Specific types of rotary power weeders are designed for operating on both waterlogged and dry soils that allow using the technology in flooded lowlands as well as rainfed or irrigated upland paddies.

**Composition.** Walking equipment for weeding between lines of rice have one or more wheels fitted with J-shaped blades pointing against the direction of travel that enter the soil up to a depth of 10 to 20 mm depth. The width of blades determine forward operating speeds, depth of penetration, degree of crop damage and weeding efficiency, factors that must be adjusted to different rice production conditions. Units are propelled by compact, two-stroke petrol motors with one to five horsepower and maneuvered with the handle bar mounted behind the wheel axil. Multiple



agricultural equipment manufacturers are selling completely assembled rotary power weeders, and crafters in rural communities can also construct or modify units with locally available parts.

**Application.** Rice crops have to be planted in even lines at a spacing of more than 20 cm for motorized weeders to be maneuvered easily through paddy fields and to avoid damaging the crop root, canopy systems. Depending on the level of weed infestation and rate of canopy growth, farmers are required to use the rotary power units once or twice on rice paddies for achieving a satisfactory level of weed control. The walking tractors can be operated by only one person, but to cover larger areas two or more operators working in conjunction are needed. Common herbicide and pesticide agents as well as biological control measure can be applied in rice cropping systems alongside with motorized weeding units to form integrated crop protection strategies that further improve yields. While large-scale farmers have the means and interest to buy a motorized weeder on their own, there is advantage in collective purchase and shared use, or private agricultural service contractors, for scaling the technology across low-income rice growing communities.



*Rotary power weeder from AfricaRice.*

**Commercialization and Start-up Requirements.** Motorized rotary weeders for rice paddies are commercially available in some African countries and are becoming more so with time as farmers recognize their advantage. Entering into mechanical weeding requires initial investment that is recovered over time through the resulting less expensive field operations. Start-up requires: 1) Informing rice farmers and agricultural service providers benefits of motorized weeding on labour expenditure and agronomic efficiency, 2) Importing weeding units, and training of artisans for local fabrication and maintenance, 3) Organizing collective purchase or rental of motorized weeders, and 4) Brokerage of small loans for farmers to enable initial investments for adopting mechanized weed control. As with all other farm equipment, rotary weeders require periodic maintenance and the availability of replacement parts.

**Production Cost.** The price of a hand-operated cut and bury power weeder for rice paddies with a 2-stroke petrol engine that is configured to simultaneously work on two rows ranges from US \$350 to US \$550, while a three row setup which may be more adapted for use by men under upland conditions is sold between US \$650 to US \$800. Using a three-row power weeder in lowland rice paddies requires about 10 to 13 hours to remove weeds from one hectare. Economic analysis of a single row motorized weeder for dryland rice operating at a rate of 0.026 hectare per hour showed that the fixed costs for equipment are US \$7 per hectare, while the variable costs for labour amount to US \$39, giving a total cost of nearly US \$46 for each hectare of rice field. This cost decreases as larger, multiple-row weeders are engaged.



*A paddy weeder manufactured in China.*

**Potential Profitability.** Motorized units tremendously speed up the work of clearing weeds from rice paddies, requiring up to 90% less time as compared to hand, and thus reduce costs of labour. Mechanized units are clearing 75% to 80% of all weeds while this efficiency increases to 90% with hand weeding, but the savings in time and cost make it possible for farmers to carry out multiple passes before the canopy of rice crops close. Grain yields and water use efficiency in paddy fields

that are kept free of weeds can be 10 times higher compared to those that are heavily infested. Large gains in fertilizer and pesticide application can be achieved by controlling weed infestation with mechanized units which allows farmers to enhance returns on investment, and to use fewer inputs.

**Client Segmentation.** Power weeding technologies are largely limited to associations of rice farmers and commercial rice producers. The supply, maintenance and contracted use of this equipment also offer an opportunity for developing service businesses in rural communities.

**Licensing Requirements.** As this equipment is manufactured and distributed by the private sector, including multi-national companies, their technologies are not considered to be Regional Public Goods. Licensing protection opens opportunity for franchise distribution and product representation by agribusinesses in rice growing areas. Blueprints and detailed building manuals for some motorized rice paddy weeders are freely available and may be fabricated without license.

## Technology 8. “RiceAdvice” Digital Support for Best Practices

**Summary.** Information about the best agronomic and management strategies for rice cultivation may be difficult to access by millions of farmers in remote areas of Africa. In addition, extension services often provide generalized recommendations that may not be suited to specific farmer conditions. To alleviate this situation, the “RiceAdvice” mobile phone application was developed by AfricaRice and its partners to generate field-specific guidelines for paddy rice production. Decision support on fertilizer use and weed management is provided through the digital platform, enabling farmers to realize higher rice grain yields and returns from their investments. The improvements of extension services through RiceAdvice are tackling practical and financial barriers that hold back widespread adoption of sustainable farming practices and value chain innovation as a whole. For more information on this topic contact Dr. Kazuki Saito and Dr. Sidi Sanyang of AfricaRice by email at [k.saito@cgiar.org](mailto:k.saito@cgiar.org) and [s.sanyang@cgiar.org](mailto:s.sanyang@cgiar.org).

Step 1: Download RiceAdvice  
from Google Play on **smartphone** or tablet



Step 2: Fill in farmers' personal  
condition  
rice growing condition, typical practices, expected  
sowing date, fertilizer availability and market price



Step 3: Set yield targets  
based on available budget or desired production  
level

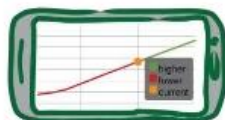

Step 4: Get a  
personalized advice  
including a crop calendar,  
fertilizer plan, recommended rice  
variety and other good  
agricultural practices



**Technical Description.** RiceAdvice is built as an interactive decision support tool. It formulates guidelines on the basis of farmers’ answers to multiple choice questions about farm conditions, cropping calendar, soil management, nutrient inputs, weed types, available equipment, financial resources, target yields and market position. Completing the questionnaires takes about 10 minutes and is either assisted by intermediary extension agents or by the farmers themselves. RiceAdvice

identifies the appropriate type, amount and application time for inorganic fertilizers and considers local prices so that farmers optimize their investments. The agronomy module sets yield objectives according to the disposable budget for soil and nutrient management practices. Using the weed manager module the most efficient and cost-effective control strategies before, during and after the rice cropping season are found that match the level of infestation, and the supply of labour and equipment. A series of recommendations are returned by the RiceAdvice applications from which farmer can pick a preferred choice. In this way, products and services are recommended to rice farmers in an orchestrated manner that lead to greater productivity and stronger positions along the rice value chain.

**Uses.** The RiceAdvice applications offer decision support for irrigated and rainfed lowland rice production systems, as well as upland paddy fields. At current, recommendations on crop, fertilizer, soil and weed management practices are fully functional for major rice growing areas in West African countries including Senegal, Nigeria, Mali, Burkina Faso, Ghana, Togo, Benin and Ivory Coast. Elaborate testing and optimization of decision support has also been carried out in different parts of Ethiopia, Madagascar, Mauritania, Tanzania, Niger, Democratic Republic of Congo and Rwanda.

**Composition.** RiceAdvice is operated on Android smartphones and tablets, and available in English and French, with other language versions being planned. The app has extensive offline capabilities allowing it to be used without an internet connection, but an active connection are required from time to time to synchronize information with data servers. The applications are Agronomic and is consistent with other training tools and management guidelines offered by AfricaRice.

**Application.** First, questions of the RiceAdvice tools have to be completed for providing information about growing conditions, typical practices, scheduled planting date, available equipment, prevalent types of weed, fertilizer availability and market prices. Next, farmers need to enter the budget at their disposal for investments and the desired production level upon which yield targets are selected. After these steps, the tool generates personalized recommendations on the rice variety, fertilizer plan, crop management and good agronomic practices. Detailed manuals and tutorials are available on how to use the RiceAdvice application, and an intuitive interface is provided so that farmers can use it on their own. The decision support for rice cultivation can also be made accessible to farmers through public extension services or private agricultural companies, and be embedded with consulting and equipment rental.

**Commercialization and Start-up Requirements.** The RiceAdvice application has been successfully released in multiple countries across SSA and is under way in many other rice growing areas. Equipment and agro-inputs for best practices are available from agro-dealers in major rice production areas. Widespread adoption of this digital decision support tool for rice farmers can be achieved by: 1) Identifying suitable business models for providing RiceAdvice services to small-scale and commercial farmers, 2) Campaigning about benefits of the decision support tool and how it can be accessed, and 3) Enabling investments in fertilizer and weed management technologies that accompany the apps recommendations. The RiceAdvice app can be freely downloaded from Google Play Store. Site visits by trained extension agents to help rice farmers access the tools, complete the questionnaires and elucidate the recommendations improves the use of this tool. This cost is best covered by national extension services, fees charged by commercial agricultural service providers, or a mix of public and private funds.

**Client Segmentation and Potential Profitability.** The digital decision support tool is useful to small-scale and commercial rice growers, national extension agencies and private agricultural service providers. The three main advantages of the RiceAdvice application cited by farmers are greater yields, enhanced income and reduced fertilizer use. Farmers using RiceAdvice recommendations have seen average yield gains of 0.6 to 1.8 ton/ha, and revenue increases of US \$100/ha to \$200/ha. Savings in fertilizer expenditure are primarily achieved by using only nitrogen fertilizers (urea) instead of compound fertilizers with nitrogen, phosphate and potassium. Monitoring has shown that

the overall efficiency of labour and agro-inputs was increased by up to 25% on paddy production systems where practices from RiceAdvice were followed. Use of RiceAdvice application has also demonstrated to create higher demand for other agricultural services, and the market for recommendations offers employment opportunities in rural communities.

**Licensing Requirements.** No licenses are required for using the RiceAdvice tools. The RiceAdvice applications have been developed by AfricaRice and are disseminated as a public good across SSA.

### RiceAdvice Business Model: Youth service providers and Input dealers in rice value chain

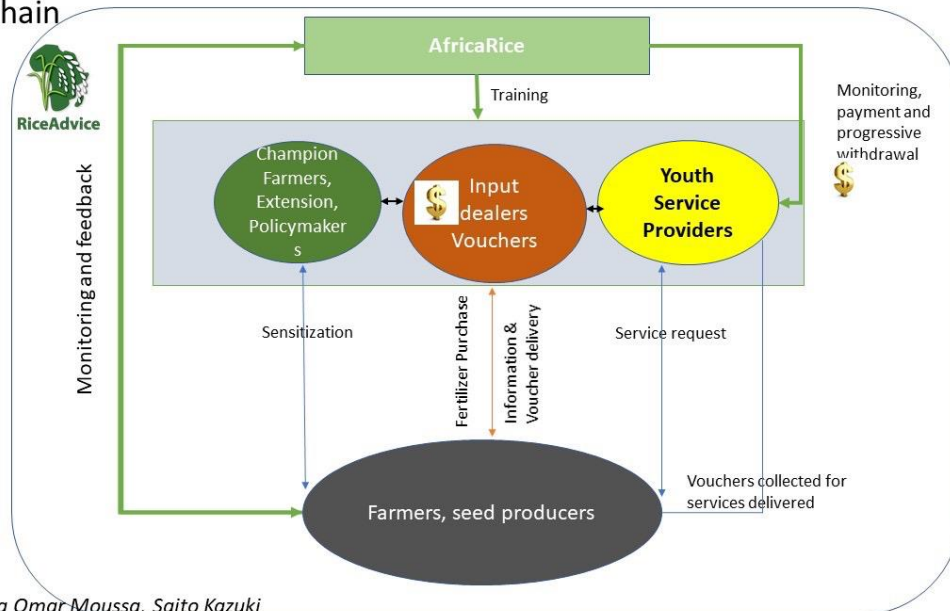

*Sidi Sanyang, Abiba Omar Moussa, Saito Kazuki*

## Technology 9. Axial Flow Thresher and Quality Milling

**Summary.** Threshing is the process of separating rice grain from the panicle after harvest, and milling remove the husk (hull) and the bran layers to produce an edible kernel that is free of impurities. Both operations are of great importance to enhance the physical, cooking and eating quality of rice that represent necessary value addition steps prior to sales to consumers. Most rice farmers in Sub-Saharan Africa rely upon traditional threshing methods where the mature rice grain is separated from the panicle when humans or animals trample on them or when the dried panicle is beaten on a hard object. This first step in threshing causes high losses due to grain breakage and un-recovered grains in poorly threshed panicles or disperse. Manual milling is performed by soaking the kernels in water and rubbing them against each other to peel off the bran or by pounding rough rice in a mortar. These artisanal practices are both time and labour consumptive, making it difficult to process large volumes of rice to high standards. Mechanized equipment for threshing and milling are well known but little adopted across rice growing areas of Africa. This is due to the required capital investment and a lack of expertise in the management of these equipment; notwithstanding the mechanization of threshing and polishing operations across smallholder rice producing communities are critical



*Motorized thresher in operation.*

humans or animals trample on them or when the dried panicle is beaten on a hard object. This first step in threshing causes high losses due to grain breakage and un-recovered grains in poorly threshed panicles or disperse. Manual milling is performed by soaking the kernels in water and rubbing them against each other to peel off the bran or by pounding rough rice in a mortar. These artisanal practices are both time and labour consumptive, making it difficult to process large volumes of rice to high standards. Mechanized equipment for threshing and milling are well known but little adopted across rice growing areas of Africa. This is due to the required capital investment and a lack of expertise in the management of these equipment; notwithstanding the mechanization of threshing and polishing operations across smallholder rice producing communities are critical



elements of agricultural transformation. For more information on this topic contact Dr. Sali Atanga Ndindeng and Dr. Sidi Sanyang of AfricaRice by email at [s.ndindeng@cgiar.org](mailto:s.ndindeng@cgiar.org) and [s.sanyang@cgiar.org](mailto:s.sanyang@cgiar.org).

**Technical Description.** Modern, motorized axial flow threshing equipment use a rotating drum in which rice grains move between the concave and drum for several complete turns causing multiple impacts as the produce moves along the length of the drum. Rice panicles are fully removed from grains in the thresher and separated through a set of sieves and a blower. The drum is the core working device of a thresher and its configuration has a major influence on the energy efficiency, power requirement and seed loss of the process. A mechanical rice milling system on the other hand, can be a one or two step or a multi step process. The one step mills (e.g. engelberg or emery disc type) are mills whereby dehulling and polishing are done in same compartment while the two step type mills (e.g. SB10 series), dehulling is done in the first step while the second step is the polishing process with both happening in different compartments. A multi-step mill has additional processes beginning with pre-cleaning, dehulling, paddy separation, polishing, grading etc. happening in different compartments. Two-step and multi-step mills record higher milling returns (>60%), head rice yield (57%) and cleaner rice than the one step mills. In addition, these milling units produce separate husk and bran that can be further exploited for the production of value added products whereas the in the one step mill, the husk and bran are mixed making limiting its exploitation to livestock feed. Self-contained mobile motorized threshers and mills for rice are available from agricultural equipment manufacturers that can be brought close to the paddy fields of farmers and allow processing large volumes of high-quality grain while keeping costs low. Compact diesel/petrol generators and solar panel installations are used in mobile units to supply power for threshing and milling of rice, making it to operate in areas without national grid electrification.

**Uses.** Motorized axial-flow threshers and two or multi-step mills offer major practical and economic advantages for value addition in all major rice production zones of Africa, both at small-scale and larger commercial levels. The high degree of mobility and cost-effectiveness achieved by such mobile rice processing units make it very suitable for regions where factories are few, and road and electricity infrastructures fall short, like is the case in many of the continent's rural regions. Sizes and configurations of equipment outfits can be easily adapted to different contexts and objectives of rice farmers, making it possible to bring the modern mechanized technologies for threshing and milling to any community in SSA.

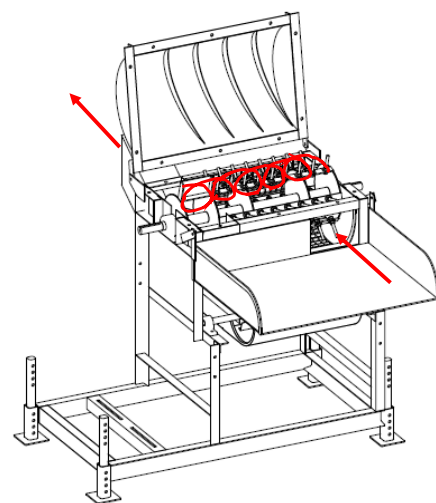

*Axial flow principle*

**Composition.** Axial flow threshing drums are made of a long cylinder lined by spikes or rasp bars on its inner surface, a thresher with spike teeth, a thresher cover with helical blades, and a stationary concave that is perforated to enable the product to drop by gravity into a collector. Rotational speeds of the thresher are conveyed from the engine using a pulley and belt. Two-step and multi-step mill have two adjustable rubber rolls in the dehulling compartment with the one on the right rotating clockwise and the one on the left rotating anti-clockwise. By adjusting the distances between the two rubber rolls, paddy of different sizes can be dehull efficiently. The polishing system can be the abrasive or friction type. Abrasive types of rice polishers are existing of a cone-shaped moving stone or carborundum surface and stationary screen, whereas friction types of rice polishers have a steel-ribbed cylinder rotating inside a metal-plated cylinder that are mounted horizontally. Both kinds of automated polishers can be fitted with a water spraying system for high gloss finishes.

All key parts of threshers and mills are made of stainless steel that make it long-lasting and easy to keep in hygienic conditions.

**Application.** Threshing of rice is normally done when the grain moisture content is between 20-22%, if it is higher or lower the efficiency goes down and grain damage increases. Rotational speeds of the thresher can be adjusted according to the desired rate of processing and power consumption, but have to be optimized to avoid cracking of grains and incomplete removal of paddy from panicle. Maximum threshing productivity and efficiency are achieved at higher rotational speeds and feed-in rates, whereas minimum power is used by automated rice threshers when rotating speeds and feed-in rates are lower. Trailer-mounted thresher units powered by an 18 to 24 horsepower motor have a rice panicle in-take capacity of 2 ton/hr, and an unhusked grain output rate of 0.5-0.75 ton/hr. Coupling optimum harvesting time with mechanical threshing has been shown to reduce grain loss from 23 to 2%. For mechanical milling equipment, the rotational speed of the cylindrical chamber and roller wheel must be sufficiently fast to achieve satisfactory productivity and quality, but not too fast as that causes grain breakage and loss. The processing capacity of mills goes from 50 to 100 kg per hour for smaller bench-top systems, to 300 to 500 kg/hr for two step trailer-mounted systems. It is possible for local artisans to fabricate motorized threshing and milling units since all building materials and equipment are readily accessible to rural communities in African countries however, thorough quality control is required.

**Commercialization and Start-up Requirements.**

Mechanized threshing and milling technologies are commercially available in many African countries although some equipment must be imported or modified.

Industrial-scale operations require considerable investment but may be embedded with existing grain processing operations. Value addition of rice grains can be widely promoted by

following these steps: 1) Inform rice farmers, cooperatives and millers about the benefits of motorized threshers and mills for increasing value addition and market access, and reducing post-harvest costs and losses, 2) Identify suitable setup and size of mobile rice processing equipment, 3) Establish reliable supply of rice by drawing up contracts and delivery schedules for farmers, and 4) Provide loans to community-based and commercial processors for acquiring mobile units, and schedule threshing and milling services.

**Production Cost.** Trailer-sized rice threshing power equipment with an unhusked grain output capacity of 0.5 to 0.75 ton per hour costs about US \$4,500 inclusive of the engine, whereas thresher systems with higher rates of throughput are sold by manufacturers for US \$12,000. Prices of small bench-top mills from commercial retailers start at US \$3,000, while larger advanced dehullers and whiteners cost about US \$15,000. The main operational expenses for the motorized rice threshing and mills are the wages of trained personnel to feed panicles into the systems and bag up the clean rice grains, maintenance of equipment, and the generator fuel or electricity to power equipment.

**Client Segmentation, Potential Profitability and Licensing Requirements.** Both of the motorized rice processing technologies are applicable for commercial food processors and manufacturers, as well as small-scale businesses and farmer associations. It requires local and regional demand for high-quality rice grain such as those being imported. Self-contained mobile rice threshing and milling



*A two step rice mill.*

units significantly reduce processing costs by bringing the factory services closer to farms, and greatly increase the volumes of rice grains that can be supplied to markets. Major gains in quality and efficiency are realized since manual threshing causes up to 30% of grains to break while for motorized threshers losses can be as low as 4%. The high value and demand of clean glossy rice grains on markets give mechanized rice processors the ability to substantially enhance incomes for farmers and processors further down the value chain. Equipment rental and skilled labour services to run processing units offer decent rural employment. Processing of rice with motorized units must comply with national regulations and standards for manufacturing of food products in order to safely access markets. Different designs of motorized threshers and mills are developed and disseminated as a public good, a large number of them by AfricaRice and the International Rice Research Institute. Commercially marketed rice processor unit are under intellectual property.

## Technology 10. GEM Parboiling and Rice Flour Production

**Summary.** Parboiling is a process whereby rice grains are steeped in cold or warm water and then heated by steam pressure or boiling water to gelatinize starch with minimum grain swelling, before being dried slowly. The main reason for parboiling is to reduce improve grain translucency and reduce breakages during parboiling. The resulting parboiled product cooks quicker and its nutritional, flavor and textural characteristics are improved, making it more appealing to consumers. Traditionally, parboiling is conducted in a cast iron pot with a false bottom for soaking and steaming that is heated above an open wood fire, exposing processors to hazardous smoke and heat. A parboiling technology called Grain quality-enhancer, Energy efficient and durable Material (GEM) combines better soaking, steaming and drying to improve grain quality, reduce energy use and drudgery at the benefit of women who dominate the parboiling industry in Africa. The energy source for the GEM parboiling process can be an improved rocket brick stoves (forced air), rice husk gasifier stoves or their combinations. Similarly, farmers and traders can add value by grinding rice especially broken rice into flour which allows storing it for several months and to include it into a variety of processed food products such as biscuits, cakes, porridges and paste. Small to medium scale rice parboiling, milling and grinding systems are highly suitable for small to medium scale processors in major production zones of Sub-Saharan Africa. For additional information on this technology, contact Dr. Sali Atanga Ndindeng and Dr. Sidi Sanyang of AfricaRice by email at [s.ndindeng@cgiar.org](mailto:s.ndindeng@cgiar.org) and [s.sanyang@cgiar.org](mailto:s.sanyang@cgiar.org).

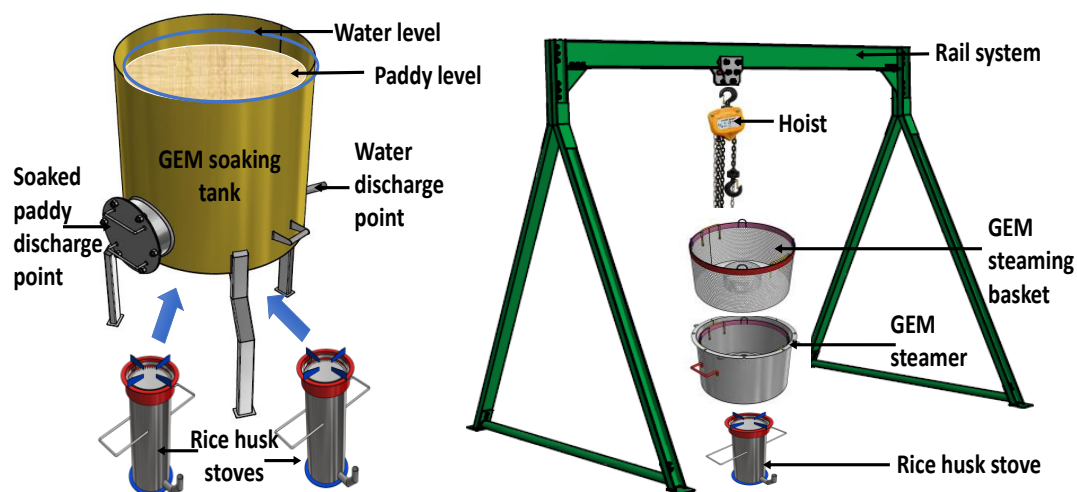

*A GEM parboiling setup with a capacity of 600 kg rice per day.*

**Technical Description.** GEM parboiling systems drastically reduce the time to steam rice, and can complete the process in 20-25 minutes as opposed to 51-78 minutes for traditional parboiling setups. Parboiling increases grain translucency and decreases chalkiness due to starch gelatinization, and makes grains harder and less brittle as a result of the swelling of starchy endosperms during steaming that remedies pre-existing defects. Food products made from parboiled rice have a lower glycemic index which improves blood pressure and decreases risk of heart disease, as well as a higher fiber content that stimulates beneficial micro-organisms in the gut, and more available vitamin B in comparison to non-parboiled rice. When carried out appropriately (high quality paddy plus GEM parboiling), the parboiling process can bring locally produced rice close to the quality of imported rice. As for dry milling, a range of power equipment is available that can produce large volumes of high-quality flour with a shelf-life of more than one year. These value addition technologies for rice crops drastically increase access and supply to markets, food processors and manufacturers at local and national scales.

**Uses.** GEM parboiling and rice flour milling offer large opportunities for adding value to farmer produce in major growing areas of Sub-Saharan Africa (SSA) where linkages to factories and markets are weak. It is best to install the GEM system close to rice milling facilities for reducing transportation cost for both paddy and parboiled rice, and improve access to rice husk, and infrastructure for drying and storage. The GEM technology can be easily built and scaled in remote communities because the materials can be locally sourced. Equipment setups for parboiling and grinding of grain can be produced local and come in different sizes that suit the needs of small-scale farmers and commercial processors in major growing areas of SSA.

**Composition.** The GEM parboiling system is not only about the equipment but the process. The GEM is composed of a paddy soaking tank, steamer, improved stoves, a hoist and rail system. The paddy soaking tank is made from stainless steel (Inox 304-L) with a water discharge point and a paddy discharge point. During soaking the paddy is submerged in hot water (initial temperature of 85-90°C) and held for 12-16 h. During this period, the temperature slowly drops to about 40°C. The steamer consists of a stainless steel (Inox 316-L) mesh basket that sits on a support in a stainless steel (Inox 304-L) tank. During steaming, boiling water in the tank produces vapor that steams the paddy in the mesh basket. The tank is closed



*Example of a small-scale rice grain flour mill*

by a tight fitting lid that reduces heat loss but the system is not pressurized. The steaming time is between 20-25 min with a capacity of 50-100 kg per batch. The stove can be a rice husk stove or an improved rocket brick wood stove. The gasifier uses electricity or a solar battery-powered 12 volt fan to propel air necessary for an efficient heat generation process. The number of stoves supplied depends on the capacity of the parboiling system. The labor-saving devices a chain hoist and rail system with a capacity of lifting 1 ton of paddy. The grain grinder can be an abrasive or a hammer mill and the grain can undergo dry or wet milling. An abrasive grain grinder has a feed-in hopper, roller table for grinding, rotary sieve for bran separation, and a compact engine and conveyor belt.

**Application.** Parboiling is conducted on rice grains with hull (rough rice) that have been passed through a winnower and washed with water. During the cleaning step the floating grains (immature or diseased) are removed from the top and the rest are transferred into the parboiling soaking tank while making sure that none of sand or gravel from the bottom gets in. Soaking the rough rice is done by adding four parts of water for three part of rice on weight basis and then heating it up to



85-90°C (depending on the variety) before letting it sit under ambient temperature for 12-16 h. The soaked rice is then put into a steaming vessel, which is put on top of the tank with boiling water for 20-25 minutes so the hot vapor can pass through. Parboiled rice is dried in the sun until it reach 18% moisture content, and then further in the shade up to 14% moisture content. After drying the parboiled rice is dehusked using a two stage mill. For long term storage (> 3 months), the rice should be dried to a moisture content of 10-12%. In the case of high-quality rice flour production, grains are washed to get rid of impurities, soaked for 8h at ambient temperature, then dried to 20% moisture content, crushed and ground into a homogenous fine powder using a grinder. For long term storage, the flour should be dried to a moisture content of 8-10%. The packaging of parboiled rice and rice flour for long term storage should be done with hermetic bags.

**Commercialization, Start-up Requirements and Production Cost.** Manufacturers of food processing equipment sell a range of parboiler and grinding systems in African countries which allows for this technology to be adopted widely. To ensure widespread uptake and satisfactory profits of these rice value addition technologies there is need for: 1) Creating awareness with processors and consumers about benefits of GEM parboiling systems, 2) Selecting the appropriate size and setup of parboiling systems for processors, and 3) Organizing continuous supply of high quality rice grain, and 4) Local and regional marketing of rice flour and derived food products. The GEM parboiling system requires a start-up capital of about US\$4000 with a life span of 20 years for the vessels and 5 years for the stoves. The GEM parboiling system has a firewood expenditure of US \$0.64 per 100 kilogram of rough rice with hulls, while for common artisanal parboiling the cost of firewood is US \$1.83 per 100 kilogram. GEM system that use rice husk wastes for generating heat can decrease fuel costs to almost zero irrespective of the quantity of rice parboiled, and such an installation costs approximately US \$400 per gasifier stove. The shorter time needed for steaming with the GEM technology saves time and brings down costs for processors and consumers compared to traditional parboiling systems. Processors have demonstrated to increase outputs of parboiled rice by a factor of 2.5 to 3 when shifting from traditional systems to the GEM technology. A small-sized flour mill for grain that can produce up to 500 kg per day costs between US \$1,000 and \$2,000, and consumes about 15 kilowatt hour of electricity.

**Framework for Businesses in GEM Rice parboiling technologies:  
Quality parboiled rice for national and regional markets**

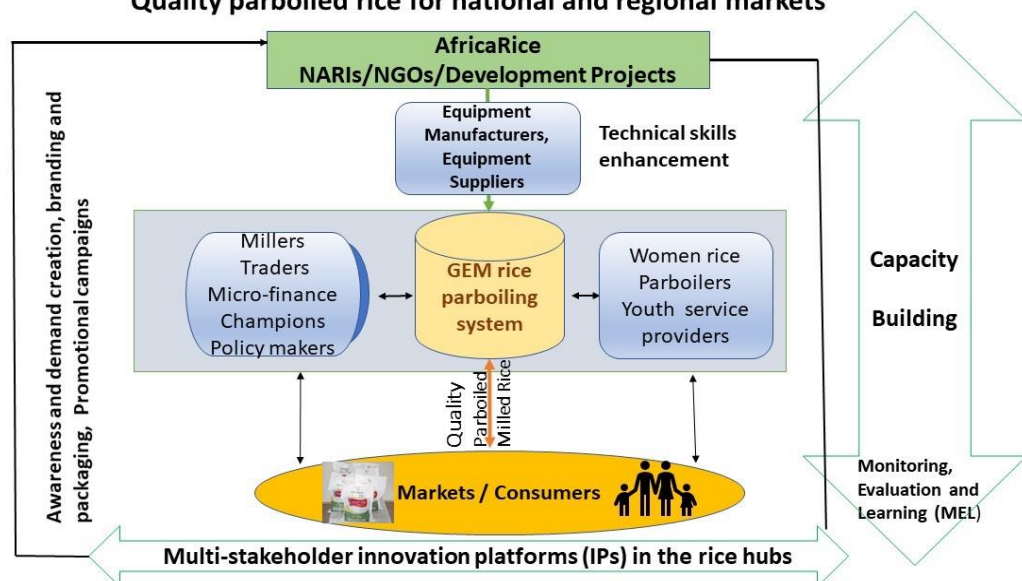

*Sidi Sanyang, Sali Atanga Ndindeng, Abiba Omar Moussa*

**Customer Segmentation and Potential Profitability.** Value addition of rice through parboiling and flour production technologies targets small-scale and commercial food processors. Making improvements in the post-harvest treatment of rice requires the involvement of a broad range of

actors following appropriate business models. The GEM technology is on high demand in regions where the consumption of parboiled rice is high, including the central and northern parts of Benin, Cameroon, Cote d'Ivoire, Ghana, Mali, Togo and most of Burkina Faso, Nigeria and Guinea Conakry. Scaling program for GEM parboiling systems in Benin showed that processors who make use of it earn an extra US \$200 per ton of rice compared to those using a traditional parboiling system. The internal rate of return for a GEM parboiling system is 70% whereas for common artisanal technologies this is 14%. Using the GEM technology, the proportion of burnt grains is less than 2% and whole grains make up 90%, with zero chalkiness and no impurities whereas in traditional systems there are up to 24% burnt grains and 60% or less whole grains, with 20% chalkiness and 5% impurities. A survey in Cameroon found that consumers were willing to pay US \$0.12 more per kilogram of rice that was parboiled with the new system as compared to premium imported parboiled rice. Increasing the quality and shelf-life of rice grown in Africa by parboiling and flour production better positions the value chain to compete with top-end imports.

**Licensing Requirements.** The building plans and manuals for GEM parboiling systems are developed and disseminated by AfricaRice as a Regional Public Good, allowing it to be used without licensing. Equipment sold by commercial manufacturers is protected by trade secrets. Processors have to comply with the food safety regulations and standards of individual countries when parboiling and grinding of rice for local and regional markets.

## TAAT as your technology broker of choice

TAAT offers its services toward the advancement of modernized agriculture. It brokers a wide range of needed technologies as represented in this catalogue and bundles them through a process of co-design into winning solutions. It recognizes that modernized agriculture is destined to serve as the main engine for economic growth in Africa's rice production areas. Change is intended to achieve not only food and nutritional security but also to meet increased trade and improved environmental quality, allowing collaborative efforts to better combine global, national and community-level interests. TAAT operates from a unique perspective to mobilize innovative solutions through better partnering that includes honest technology brokerage and effective, scalable skills development through five key mechanisms.

- ☑ **Unique understanding:** Expertise is offered in the areas of site characterization and problem identification.
- ☑ **Innovative solutions:** Leadership is provided in technology brokerage and solution bundling based upon a dynamic portfolio of candidate technologies.
- ☑ **Better partnering:** Assistance is offered in the better co-design and management of projects prompting agricultural transformation.
- ☑ **Replicable approaches:** Assistance is available to advance skill sets in technology brokerage and project management through customized Training of Trainers.
- ☑ **Honest brokerage:** An independent capacity for impact assessment and constructive learning is achieved through standardized monitoring and evaluation.

These partnership mechanisms are applied to the technologies featured in this catalogue as follows:

1. **Improved varieties of rice:** The latest improved varieties of rice becomes available to our partners through the Rice Compact led by AfricaRice. These varieties include line from the NARICA, ARICA and Orylux breeding lines used in both wetland and upland growing conditions. These varieties are not only high yielding but offer resilience to climate extremes. *These services are arranged by TAAT and AfricaRice.*
2. **Accelerated commercial licensing of improved varieties and hybrids.** TAAT's Rice Compact partner, AfricaRice operates a mechanism that accelerates and supports the licensing of improved rice varieties and hybrids to commercial seed producers. This service includes providing new varieties for testing by national authorities. *These services are arranged by TAAT through its partner AfricaRice.*
3. **Improving rice-based cropping systems.** While this catalogue features several key technologies related to rice farming, it is not intended as a grower's manual. At the same time, it recognizes that modernizing technologies related to rice production and processing are extremely important to Africa it it is to become self sufficient in this commodity. For this reason, this catalogue includes reach to irrigation services, fertilizer strategies, and weed management. All of these technologies are intended to cut across individual crop enterprises and assist African farmers to modernize their systems as a whole. It also links clients to "RiceAdvice" digital support for best practices. *Allow TAAT and its partnering expertise in soil and water management from the International Water Management Institute and the International Fertilizer Development Center to assist in the design of more robust cropping systems better able to overcome climate variation related to combinations of heat, drought, flooding and more rapidly evolving pests and pathogens.*

4. **Food systems perspective.** Agriculture, food, nutrition and public health are becoming unified into the common perspective of food systems after having been fragmented into individual disciplines for many years. Adding value to rice so that domestic production is able to compete with imports is important in this regard. Allow TAAT to assist in developing a more advanced food systems perspective and to provide more nutritious crops and processing technologies required to achieve healthier crops and people. TAAT also assists in energy savings during food preparation. *Indeed, TAAT and all of its partners hold expertise in food systems and are committed to transforming agriculture from the food, nutrition and health perspective.*

***Be assured that TAAT is prepared to partner with development investors, national projects and the private sector in a demand-driven manner; always in the spirit of participation toward the co-design and collaborative implementation of solutions that advance the modernization of African agriculture.***





## Conclusions

This catalogue provides a wide variety of options for modernizing rice production and processing in Africa. It identifies means to improve yield and nutritional value of this important grain staple, and to grow varieties that are resistant to drought and disease. It provides better options for land and fertilizer management in rice paddy cultivation, particularly by engineering irrigation surfaces, deep urea placement and foliar micronutrient application. The catalogue advances weed management by signalling the importance of motorized in-row weeders, and also the broader adoption of good agronomic practices through digital decision support tool that provide farmers with diagnostic recommendations. Several options for mechanized processing of harvested rice are described that drastically lower the costs of labour and increase the value of its milled rice. While rice is an important human food, it may also be processed into a wide variety of products and the preparation of high quality flour and possibly starches. Technologies featured in this toolkit offer opportunities for rice growing communities in SSA to access the high-end of the value chain and global market place, which can boost incomes of small-scale farmers and commercial agribusinesses.

This catalogue was prepared with a variety of users in mind whether they be producers, agents of agricultural development or private sector investors. Farmers can use many of these catalogue items as production guidelines. Those from the public sector can make use of the catalogue as a whole and design agricultural projects involving rice around its toolkit of modernizing the rice sector. Members of the private sector, including growers, input producers, manufacturers, processors and investors can also benefit from the contents of this catalogue. Indeed, the Technologies for African Agricultural Transformation Program's Clearinghouse welcomes feedback on the contents.

## Information Sources



TAAT Clearinghouse. 2018. **TAAT Technology Toolkits and their Strategic Deployment**. Clearinghouse Technical Report Series 001, Technologies for African Agricultural Transformation, Clearinghouse Office, Cotonou, Benin. 18 pp.



Defoer, T., M.C.S. Wopereis, P. Idinoba, K.L. Kadisha, S. Diack and M. Gaye, 2009. **Curriculum for Participatory Learning and Action Research (PLAR) for Integrated Rice Management (IRM) in Inland Valleys of Sub-Saharan Africa: Facilitator's Manual**. Africa Rice, Cotonou, Benin. 184 pp

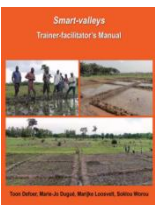

Defoer, T, Dugué, M-J, Loosvelt, M, and Worou, S. 2017. **Smart-valleys: Trainer-facilitator's manual**. Africa Rice Center, Abidjan, Côte d'Ivoire. 130 pp.



International Fertilizer Development Center (IFDC). 2016. **Rapid introduction and market development for urea deep placement technology for lowland transplanted rice**. IFDC, Muscle Shoals, Alabama, USA. 135 pp.

## **Acknowledgements**

This catalogue of TAAT technology toolkits results from a unique blend of two parallel efforts; the Technologies for African Agricultural Transformation Program (TAAT) and the Product Platform of Agricultural Solutions (ProPAS). Dries Roobroeck and Paul L. Woomer of the TAAT Clearinghouse compiled this catalogue. Ernest Asiedu from AfricaRice is the TAAT Rice Compact Leader, and he and his team are advancing the technologies presented in this catalogue across Africa. Caroline Akinyi and Phaniel Ayuka assisted in the construction of the ProPAS internet site (see <http://propas.iita.org/>) and their efforts were supervised by Bernard Vanlauwe, Tonny Omwansa, and Olatunbosun Obileye of the International Institute of Tropical Agriculture (IITA). The TAAT Clearinghouse is funded through a project funded by the Bill and Melinda Gates Foundation and the larger TAAT Program, including its Rice Compact, is supported through the African Development Fund of the African Development Bank. For more information on the TAAT Program, please visit its website at <https://www.iita.org/technologies-for-african-agricultural-transformation-taat/>.

## **Technologies for African Agricultural Transformation (TAAT) and its Clearinghouse Office**

The developmental objective of TAAT is to rapidly expand access of smallholder farmers to high yielding agricultural technologies that improve their food production, assure food security and raise rural incomes. This goal is achieved by delivering regional public goods for rapidly scaling up agricultural technologies across similar agro-ecological zones. This result is achieved through three principal mechanisms; 1) creating an enabling environment for technology adoption by farmers, 2) facilitating effective delivery of these technologies to farmers through a structured Regional Technology Delivery Infrastructure and 3) raising agricultural production and productivity through strategic interventions that include improved crop varieties and animal breeds, accompanying good management practices and vigorous farmer outreach campaigns at the Regional Member Country level. The important roles of sound policies, empowering women and youth, strengthening extension systems and engaging with the private sector is implicit within this strategy. The Clearinghouse is the body within TAAT that decides which technologies should be disseminated. Moreover, it is tasked with the responsibility to guide the deployment of proven agricultural technologies to scale in a commercially sustainable fashion through the establishment of partnerships that provide access to expertise required to design, implement, and monitor the progress of technology dissemination campaigns. In this way, the Clearinghouse is essentially an agricultural transformation incubation platform, aimed at facilitating partnerships and strengthening national agricultural development programs to reach millions of farmers with appropriate agricultural technologies.

***Dr. Innocent Musabyimana, Head of the TAAT Clearinghouse***

**Back cover photographic credit:** Women farmers in Madagascar harvesting NERICA rice from their paddy fields. Photo credit: Japan International Cooperation Agency.



# Rice Technology Toolkit Catalogue



*In collaboration with*

